

# **DigiTRAK<sup>®</sup> F5<sup>®</sup>**

## **SST<sup>®</sup> Guidance System**

### **Operator's Manual**



**DCI Headquarters**  
19625 62nd Ave. S., Suite B-103  
Kent, Washington 98032 USA  
*Tel* 425 251 0559 / 800 288 3610 *Fax* 253 395 2800  
*E-mail* DCI@digital-control.com [www.digitrak.com](http://www.digitrak.com)

**DCI Europe**  
Kurmainzer Strasse 56  
D-97836 Bischbrunn  
Germany  
*Tel* +49(0) 9394 990 990  
*Fax* +49(0) 9394 990 999  
DCI.Europe@digital-control.com

**DCI India**  
DTJ 1023, DLF Tower A  
Jasola District Center  
New Delhi 110 044, India  
*Tel* +91(0) 11 4507 0444  
*Fax* +91(0) 11 4507 0440  
DCI.India@digital-control.com

**DCI China**  
No. 368, Xingle Road  
Huacao Town, Minhang District  
Shanghai P.R.C. 201107  
*Tel* +86(0) 21 6432 5186  
*Fax* +86(0) 21 6432 5187  
DCI.China@digital-control.com

**DCI Australia**  
2/9 Frinton Street  
Southport, Queensland 4215  
Australia  
*Tel* +61(0) 7 5531 4283  
*Fax* +61(0) 7 5531 2617  
DCI.Australia@digital-control.com

**DCI Russia**  
420059 Pavlyukhina Street  
104, Kazan  
Russia  
*Tel* +7 843 277 52 22  
*Fax* +7 843 277 52 07  
DCI.Russia@digital-control.com

3-3500-00-A1

© 2011 by Digital Control Incorporated. All rights reserved. October 2011 edition.

## Trademarks

The DCI logo, CableLink<sup>®</sup>, DataLog<sup>®</sup>, DigiTrak<sup>®</sup>, Eclipse<sup>®</sup>, F2<sup>®</sup>, F5<sup>®</sup>, iGPS<sup>®</sup>, MFD<sup>®</sup>, SST<sup>®</sup>, *target-in-the-box*<sup>®</sup>, *Target Steering*<sup>®</sup>, and TensiTrak<sup>®</sup> are U.S. registered trademarks and DucTrak<sup>™</sup>, F Series<sup>™</sup>, FSD<sup>™</sup>, *FasTrak*<sup>™</sup>, LWD<sup>™</sup>, SE<sup>™</sup>, SED<sup>™</sup>, SuperCell<sup>™</sup>, and TeleLock<sup>™</sup> are trademarks of Digital Control Incorporated.

## Limited Warranty

All products manufactured and sold by Digital Control Incorporated (DCI) are subject to the terms of a Limited Warranty. A copy of the Limited Warranty is included at the end of this manual; it can also be obtained by contacting DCI Customer Service, 425-251-0559 or 800-288-3610, or by connecting to DCI's website, [www.digitrak.com](http://www.digitrak.com).

## Important Notice

All statements, technical information, and recommendations related to the products of DCI are based on information believed to be reliable, but the accuracy or completeness thereof is not warranted. Before utilizing any DCI product, the user should determine the suitability of the product for its intended use. All statements herein refer to DCI products as delivered by DCI and do not apply to any user customizations not authorized by DCI nor to any third-party products. Nothing herein shall constitute any warranty by DCI nor will anything herein be deemed to modify the terms of DCI's existing Limited Warranty applicable to all DCI products. The most recent version of this manual is available on DCI's website.

## FCC Compliance Statement

This equipment complies with Part 15 of the Rules of the FCC. Operation is subject to the following two conditions: (1) this device may not cause harmful interference, and (2) this device must accept any interference received, including interference that may cause undesired operation. DCI is responsible for FCC compliance in the United States: Digital Control Incorporated, 19625 62nd Ave. S., Suite B-103, Kent, WA 98032; phone 425-251-0559 or 800-288-3610.

Changes or modifications to the DCI equipment not expressly approved and carried out by DCI will void the user's Limited Warranty and the FCC's authorization to operate the equipment.

## CE Requirements



DigiTrak receivers are classified as Class 2 radio equipment per the R&TTE Directive and may not be legal to operate or require a user license to operate in some countries. The list of restrictions and the required declarations of conformity are available on DCI's website, [www.digitrak.com](http://www.digitrak.com), under the Service & Support tab. Click on DOWNLOADS and select from the CE Documents pull-down menu to download, view, or print the documents.

## *Table of Contents*

|  |    |
|--|----|
| SAFETY PRECAUTIONS AND WARNINGS.....   | 6  |
| DEAR CUSTOMER:.....  | 8  |
| INTRODUCTION.....  | 9  |
| SYSTEM COMPONENTS.....   | 13 |
| SST Transmitter with Magnetic Shield .....   | 13 |
| F5 SST Receiver .....  | 14 |
| SST Remote Display .....   | 15 |
| Multi-Function Cable Box (MFCB).....   | 16 |
| Laptop Computer with LWD Software .....  | 17 |
| Non-DCI Components That Are Needed.....  | 18 |
| SYSTEM OPERATING INSTRUCTIONS .....  | 19 |
| Setting Up SST Laptop.....   | 19 |
| 1. Plot Topography, Drill Plan, and Planned Deviation.....                                       | 19 |
| Setting Up Equipment and Site .....  | 19 |
| 2. Establish Bore Path Reference Line and Mark Bore Path.....                                    | 19 |
| 3. Assemble and Torque-up Non-Magnetic Housing to Non-Mag Tool.....                              | 19 |
| 4. Align Drill to Marked Bore Path.....  | 20 |
| 5. Position & Align Non-mag Tooling Assembly onto Marked Bore Path .....                         | 20 |
| 6. Stage SST Equipment and Power Source Adjacent to Tooling Assembly .....                       | 21 |
| 7. Connect and Power Up F5 SST Equipment .....   | 22 |
| 8. Measure SST Transmitter Current Draw .....  | 23 |
| 9. Install SST Transmitter into Aligned Non-mag Tooling Assembly .....                           | 23 |
| Setting Reference Heading and Roll Offset .....  | 23 |
| 10. Set Reference Heading – Shoot the Probe .....  | 23 |
| 11. Set Roll Offset on Remote (if needed) .....  | 25 |
| 12. Set Roll Offset on Receiver (if needed) .....  | 26 |
| Calibrating SST Transmitter and Confirming Proper System Operation.....                          | 28 |
| 13. Calibrate SST Transmitter to Receiver .....  | 28 |
| 14. Measure SST Transmitter Current Draw in Housing .....  | 28 |
| 15. Verify Pitch Readings Using Digital Level.....   | 28 |
| 16. Connect SST Equipment to the Drill .....   | 29 |
| 17. Start LWD Program and Confirm System Operation .....   | 30 |
| Logging Drill Run .....  | 32 |
| 18. Log Rod 0 (zero) .....   | 32 |
| 19. Locate (if possible), Override Data (if necessary), and Continue to Log .....                | 32 |
| 20. Compensate for Differences Between Tool’s Logged Position Data<br>and Tracked Position ..... | 33 |
| 21. Pull Back Rods, Resteer, and Relog.....  | 34 |
| 22. Save Drill Data Occasionally.....  | 35 |
| 23. Log Last Rod.....  | 35 |
| 24. Save Project.....  | 35 |
| Summary of Basic Operating Procedure.....  | 36 |

## **Table of Contents (Continued)**

|  |    |
|--|----|
| LWD SOFTWARE INSTRUCTIONS.....   | 37 |
| Starting LWD Program and Opening Files .....                               | 37 |
| Menu and Tool Bars .....   | 39 |
| File Menu Commands.....  | 39 |
| Edit Menu Commands.....  | 40 |
| View Menu Commands.....  | 40 |
| Window Menu Commands.....  | 41 |
| Help Menu Commands .....   | 41 |
| Information Fields .....   | 41 |
| Site Information .....   | 41 |
| Job Information .....  | 42 |
| Data Tables.....   | 42 |
| Data Points .....  | 42 |
| Topography.....  | 43 |
| Drill Plan .....   | 43 |
| Confidence Points .....  | 44 |
| Chart Area.....  | 44 |
| Profile View Chart.....  | 45 |
| Plan View Chart.....   | 45 |
| Editing and Annotating Charts.....   | 46 |
| Drawing Shapes and Adding Captions .....                                   | 46 |
| Selecting and Editing Shapes.....  | 47 |
| Adding and Editing Captions .....  | 47 |
| Editing Chart Properties .....   | 47 |
| Printing and Previewing Project Files.....                                 | 48 |
| Saving Project Files .....   | 48 |
| E-mailing Report to Customer Who Does Not Have DigiTrak LWD software ..... | 49 |
| INPUTTING AND EDITING DRILL DATA.....                                      | 51 |
| Topography.....  | 51 |
| Inserting Topography Data Points .....                                     | 51 |
| Editing Topography Data Points .....                                       | 51 |
| Deleting Topography Data Points .....                                      | 52 |
| Importing Topography Data Points .....                                     | 52 |
| Drill Plan .....   | 53 |
| Inserting Drill Plan Data Points .....                                     | 53 |
| Editing Drill Plan Data Points .....                                       | 54 |
| Deleting Drill Plan Data Points.....                                       | 54 |
| Importing Drill Plan Data Points .....                                     | 55 |
| Confidence Points .....  | 56 |
| Job Information.....   | 57 |
| Upload Control.....  | 58 |

## ***Table of Contents (Continued)***

|  |    |
|--|----|
| INPUTTING AND EDITING DRILL DATA (Continued)                         |    |
| Steering Tool Data Points.....                                       | 60 |
| Editing Steering Tool Data Points .....                              | 60 |
| Inserting Steering Tool Data Points .....                            | 60 |
| Removing Steering Tool Data Points.....                              | 61 |
| Hiding Steering Tool Data Points.....                                | 61 |
| APPENDIX A: SYSTEM SPECIFICATIONS AND MAINTENANCE REQUIREMENTS ..... | 63 |
| Power Requirements .....   | 63 |
| Environmental Requirements .....                                     | 63 |
| General SST Transmitter Care Instructions .....                      | 64 |
| General Cable Box Care Instructions .....                            | 64 |
| APPENDIX B: TRANSMITTER WIRE REPAIR OR REPLACEMENT .....             | 65 |
| LIMITED WARRANTY   |    |

## *Safety Precautions and Warnings*

**IMPORTANT NOTE:** All operators must read and understand the following safety precautions and warnings and must review this operator's manual as well as the manual that came with your DigiTrak F5 Locating System before using the DigiTrak F5 SST Guidance System.

☠ Serious injury and death can result if underground drilling equipment makes contact with an underground utility such as a high-voltage electrical cable or a natural gas line.

▼ Substantial property damage and liability can result if underground drilling equipment makes contact with an underground utility such as a telephone, cable TV, fiber-optic, water, or sewer line.

⌚ Work slowdowns and cost overruns can occur if drilling operators do not use the drilling or locating equipment correctly to obtain proper performance.

💡 DCI equipment is not explosion-proof and should never be used near flammable or explosive substances.

- Directional drilling operators **MUST** at all times:
  - Understand the safe and proper operation of drilling and locating equipment, including the use of ground mats and proper grounding procedures.
  - Ensure that all underground utilities have been located, exposed, and marked accurately prior to drilling.
  - Wear protective safety clothing such as dielectric boots, gloves, hard-hats, high-visibility vests, and safety glasses.
  - Locate and track the transmitter in the drill head accurately and correctly during drilling.
  - Maintain a minimum distance of 8 in. (20 cm) from the front of the receiver to the user's torso to ensure compliance with FCC requirements.
  - Comply with federal, state, and local governmental regulations (e.g., OSHA).
  - Follow all other safety procedures.
- DigiTrak locating systems cannot be used to locate utilities.
- In the event of electrostatic shock, the display screen may go blank. No data loss will occur. Click the trigger to reset the receiver; toggle down to reset the remote display.
- Continued exposure of the transmitter to heat, due to frictional heating of the drill head, can cause inaccurate information to be displayed and may permanently damage the transmitter.



**CAUTION:** Hot surfaces can occur on the FC, ECP, and SST cable transmitters if housing requirements are not met. Always ensure that the transmitter is installed properly in the housing during use.

- Remove the batteries from all system components during shipping and prolonged storage; damage caused by leakage may occur.

## Safety Precautions and Warnings (Continued)



**BATTERY DISPOSAL:** This symbol on equipment indicates that the equipment must not be disposed of with your other household waste. Instead, it is your responsibility to dispose of such equipment by handing it over to a designated collection point for the recycling of batteries or electrical and electronic equipment. If the equipment contains a banned substance, the label will show the pollutant (Cd = Cadmium; Hg = Mercury; Pb = Lead) near this symbol. The separate collection and recycling of your waste equipment at the time of disposal will help to conserve natural resources and ensure that it is recycled in a manner that protects human health and the environment. For more information about where you can drop off your waste equipment for recycling, please contact your local city office, your household waste disposal service, or the shop where you purchased the equipment.

- The battery charger provided with your DigiTrak locating system is designed with adequate safeguards to protect you from shock and other hazards when used as specified within this document. If you use the battery charger in a manner not specified by this document, the protection provided may be impaired. Do not attempt to disassemble the battery charger. It contains no user-serviceable parts. The battery charger is not to be installed into caravans, recreational vehicles, or similar vehicles.
- Before each drilling run, test your DigiTrak locating system with the transmitter inside the drill head to confirm that it is operating properly and is providing accurate drill head location and heading information.
- During drilling, the depth will not be accurate unless:
  - The receiver has been properly calibrated and the calibration has been checked for accuracy so that the receiver shows the correct depth.
  - The transmitter has been located correctly and accurately and the receiver is directly above the transmitter in the drill head underground or at the front locate point.
  - The receiver is held at the height-above-ground distance, which has been set correctly, or placed on the ground for depth measurements.
  - The SST transmitter remains at a distance of at least 15 ft (4.6 m) from any metal or metallic objects.
- Interference can cause inaccuracies in the measurement of depth and loss of the transmitter's pitch, roll, or heading. You should always perform a background noise check prior to drilling.
  - Sources of interference include but are not limited to traffic signal loops, invisible dog fences, cable TV, power lines, fiber-trace lines, metal structures, cathodic protection, telephone lines, cell phones, transmission towers, conductive earth, salt, salt water, rebar, radio frequencies, and other unknown sources of interference.
  - Interference with the operation of the remote display may also occur from other sources operating nearby on the same frequency, such as car rental agencies using their remote check-in modules, other directional drilling locating equipment, etc.
  - Background noise must be minimal and signal strength must be at least 150 points above the background noise during all locating operations.
- Carefully review this manual and be sure you always operate your DigiTrak locating system properly to obtain accurate depth, pitch, roll, and locate points. If you have any questions about the operation of the system, please call DCI Customer Service at any of the phone numbers provided on the cover, and we will do our best to assist you.

## ***Dear Customer:***

Thank you for choosing the DigiTrak F5 SST Guidance System. We are proud of the equipment that we have been designing and building in Washington State since 1990. We believe in providing a unique, high-quality product *and* standing behind it with superior customer service and training.

Please take the time to read this entire manual—especially the section on safety. Also, please fill in the product registration card provided with this equipment, and mail it to DCI headquarters or fax it to us at 253-395-2800; you can also complete and submit the form online at our website. We will put you on the Digital Control mailing list and send you product upgrade information and our *FasTrak* newsletter.

Feel free to contact us at any of our global offices listed on the front cover if you have any problems or questions. Our Customer Service Department is available 24 hours a day, 7 days a week to provide assistance.

As the horizontal directional drilling industry grows, we're keeping our eye on the future to develop equipment that will make your job faster and easier. Stay current by visiting our website on the internet at [www.digitrak.com](http://www.digitrak.com) or by giving us a call.

We welcome questions, comments, and ideas.

Digital Control Incorporated  
Kent, Washington  
2011

## Introduction



### DigiTrak F5 SST Guidance System

The DigiTrak F5 SST Guidance System is designed for horizontal directional drilling (HDD) projects where walkover locating is difficult. It provides real-time tool information that enables accurate steering of the drill head directly from the remote display and computer interface. The SST (Short Steering Tool) transmitter is a wireline device that has an internal compass to determine heading or direction. A magnetic shield is provided for protection from magnetic fields when the transmitter is not in use, and a special non-magnetic housing is required during drilling.

Steering data is shown in real time on both the remote display at the drill rig and on the laptop computer, which can be placed up to 50 ft (15 m) away from the remote. The remote and computer are connected through the cable box, which is also connected to the SST transmitter and the power source. The F5 receiver is used for calibration and to confirm transmitter data. DCI recommends that you use a combination of walkover and non-walkover locating whenever possible to increase the capabilities and accuracy of the SST system. A standard F5 system can be upgraded to the F5 SST system.

There are some important terms and procedures that are used specifically with the SST system that you should understand. These include the following:

- Heading – Azimuth compass heading or direction measured by the SST transmitter with respect to the Earth’s North Pole. (Known as Yaw in the Eclipse steering tool system.)
- Reference heading – Azimuth heading of the SST transmitter measured when it is accurately positioned on the surveyed bore path prior to the start of the drill run. The course deviation is determined from this heading. The value for the reference heading is determined at the start of the SST operating procedure. (Known as reference yaw or Ref Yaw in the Eclipse steering tool system.)
- Shoot the probe – Term commonly used for the procedure of measuring the reference heading using the SST transmitter (probe).
- 360° roll – Standard HDD walkover systems use a “clock” roll orientation. The SST transmitter uses a 360° roll sensor with 1° increments, where 0° = 12 o’clock, 90° = 3 o’clock, 180° = 6 o’clock, and 270° = 9 o’clock.

The following types of data are displayed and recorded with the SST guidance system:

- Heading (in tenths of a degree) – Displayed on receiver and remote and recorded on computer.
- Reference heading (in tenths of a degree) – Displayed on remote and recorded on computer.
- Heading deviation (in tenths of a degree) – Amount of deviation SST transmitter is exhibiting from the reference heading; displayed on remote and recorded on computer.
- Depth (in feet or meters), pitch (in tenths of a percent or tenths of a degree), and roll (in degrees from 0–360°) – Displayed on receiver and remote when receiver is used for walkover locating; calculated depth is displayed and recorded on computer.
- Course deviation (in feet/meters) – Displayed and recorded on computer.
- Temperature (in degrees Fahrenheit or Celsius) – Displayed on receiver and remote; not recorded on computer.
- Voltage levels for power supply and SST transmitter (in volts) – Displayed on remote; not recorded on computer.
- System current (in amps) – Displayed on remote; not recorded on computer.
- Distance from drill rig and bore distance (in feet/meters) – Displayed and recorded on computer only.
- Date and time of recording – Displayed and recorded on computer only.

To further expedite wireline connection time, the SST system can be used with the DigiTrak CableLink connection system. The CableLink system is preinstalled in drill rods so that the electrical connection is made when the rods are threaded up.

This operator’s manual begins by describing the primary *System Components*—including the SST transmitter, the F5 SST receiver, the SST remote display, the multi-function cable box (MFCB), and the laptop computer with preinstalled LWD (Log-While-Drilling) software—and the other supplies needed for

using the SST system. The next section presents the *System Operating Instructions*, which cover the standard procedure for setting up and using the SST guidance system. This is followed by instructions for using the LWD computer software in general (*LWD Software Instructions*), and then by detailed information on *Inputting and Editing Drill Data* in the computer. System specifications and maintenance requirements are provided in *Appendix A*, and specific instructions for repair of the wireline components in the SST transmitter are given in *Appendix B*.

Some terms and techniques used in this manual are considered basic to the F5 locating system. If you have never used the F5 system, then you are required to read the operator's manual for the system (*DigiTrak F5 Directional Drilling Locating System Operator's Manual*) before using the SST system.

**NOTE: You must know how to operate the F5 locating system prior to operating the F5 SST guidance system.**

You also must read the instructions given in this SST system operator's manual and familiarize yourself with the various menu screens on your F5 SST receiver and remote display before using the system for a production drill. We also recommend that you review the LWD software application and the help files in the software relating to the SST (steering tool) guidance system. If you have questions, please call DCI Customer Service.

## Notes

## System Components

The F5 SST guidance system consists of the following main components, which are described in this section:

- SST transmitter – A cable transmitter with an internal compass; requires protective magnetic shield.
- F5 SST receiver – An F5 receiver upgraded with the SST capability.
- SST remote display – A multi-function remote display (DigiTrak FSD or MFD) with SST capability.
- Multi-function cable box (MFCB) – An interface unit that connects all hard-wired system components, including the SST transmitter, remote display, computer, and power source.
- Laptop computer with LWD software – A dedicated computer with LWD software preinstalled and ready to use.

In addition, some equipment, tooling, and specialty items are required for use with the SST system but are not provided by DCI. These items are identified and described at the end of this section.

### SST Transmitter with Magnetic Shield

The SST transmitter is similar to the standard cable transmitter except that it also provides heading information and requires special non-magnetic shielding and a non-magnetic housing. The heading information, in addition to the pitch and roll data, enables the drill operator to determine the SST transmitter's position and orientation, and thus allows steering of the tool.

The SST transmitter provides heading and pitch updates every 1.3 seconds and roll updates more than 3 times per second. The SST transmitter has a repairable end cap assembly; two spare assemblies are provided with the transmitter so that the cable lead and end cap components can be replaced or rebuilt as needed (see Appendix B).

Because the SST transmitter is a magnetic-sensitive device, it needs to be kept away from all magnetic sources. A protective magnetic shield, which is essentially a copper sleeve, is provided with the SST transmitter. The magnetic shield should be placed on the end of the SST transmitter at all times when the transmitter is not in use.

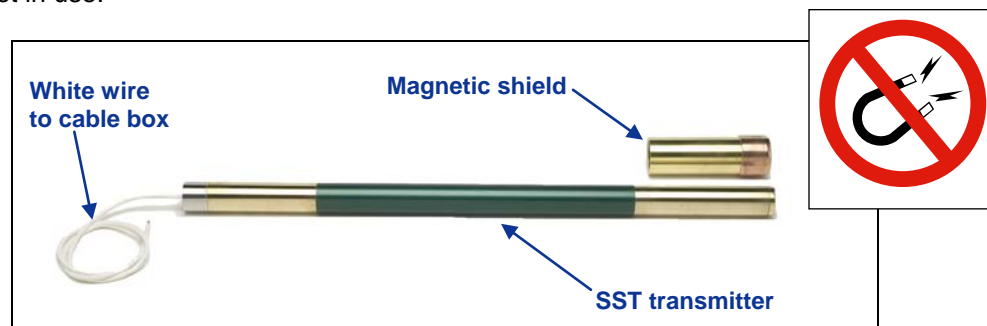

**SST Transmitter and Protective Magnetic Shield**

**NOTE:** The SST transmitter must be kept at least 5 ft (1.5 m) away from all magnets including the remote display, which has a magnetic mount that will damage the transmitter. A special non-magnetic housing is required.

The non-magnetic housing for the SST transmitter must be a rear-load housing. To prevent overheating and for optimum performance, the transmitter must be installed correctly in the housing. An extraction/insertion tool is provided with the SST transmitter for use in properly installing it into and removing it from the housing. Installation instructions are provided in the *System Operating Instructions* section.

It is critical that the slots in the drill housing meet minimum length and width requirements and be correctly positioned. DCI recommends at least three slots equally spaced around the circumference of the housing. Each slot must be at least 1/16 or 0.0625 in. (1.6 mm) wide. For accuracy, slot measurements must be taken from the inside of the housing. The SST transmitter, which is 24 in. (60.96 cm) long, requires slots in the housing that are at least 9 in. (22.9 cm) long and begin at least 8.5 in. (21.6 cm) from the front end of the transmitter, as shown below.

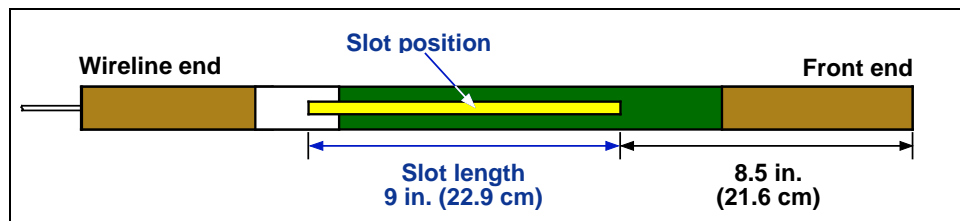

**SST Transmitter Housing Slot Requirements**

## F5 SST Receiver

The F5 SST receiver is an F5 receiver that has been upgraded with the SST capability. The receiver is used to locate the SST transmitter when walkover locating is possible and to confirm depth readings and other transmitter data. The locating procedure for the SST is the same as that for the standard F5 locating system, with simple two-button (trigger and toggle switch) operation.

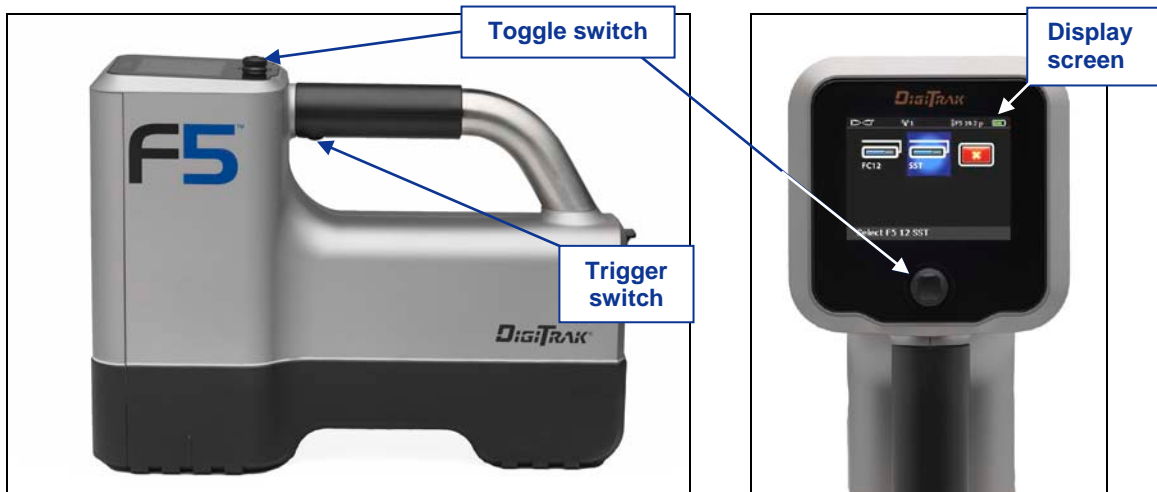

**F5 SST Receiver Side View (left) and Top View (right)**

Any F5 receiver can be upgraded to have the SST capability. The SST upgrade adds the SST option, as defined below, to the cable transmitter menu.

|  |  |
|--|--|
|  | <p><b>SST transmitter option</b> – Enables detection of an SST transmitter when the SST receiver is in locate mode. This transmitter option must be selected to calibrate and track the SST transmitter using the receiver. When an SST transmitter is selected, the SST heading information appears on the locate mode screen and the roll indicator on the receiver display shows units in degrees (from 0° to 360°) rather than the standard clock positions.</p> |
|--|--|

## SST Remote Display

The SST remote display is a multi-function remote that receives and displays real-time information including heading, pitch, roll, temperature, and battery status. Any DigiTrak F Series Display (FSD) or DigiTrak Multi-Function Display (MFD) can be upgraded to have the SST capability.

An SST remote operates much like a standard remote display, with the function buttons on the keypad (direction buttons and execute button) and the main menus operating in the same manner. The SST remote menu options include the standard options plus an option to set the reference heading. This menu option is discussed further in the *System Operating Instructions* section.

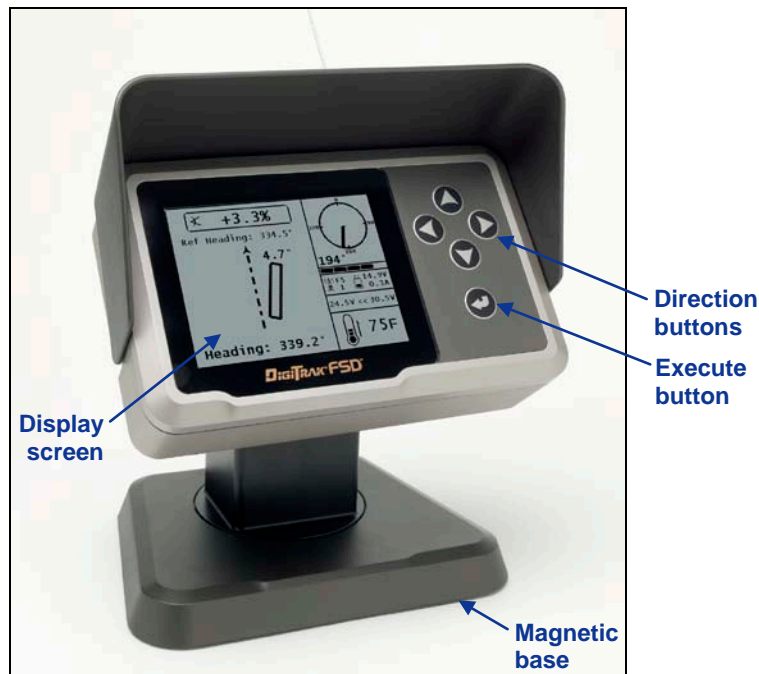

**SST Remote Display**

An SST remote operating in cable mode with an SST transmitter will show roll units in degrees (from 0° to 360°), whereas a standard remote display operating with other transmitters shows roll units that correspond to the numbers on a clock (1 through 12).

## Multi-Function Cable Box (MFCB)

The cable box routes power to the SST transmitter and the remote display and sends transmitter data to the remote and the computer laptop. It is installed between the DC power port on the back of the remote display and a DC power source.

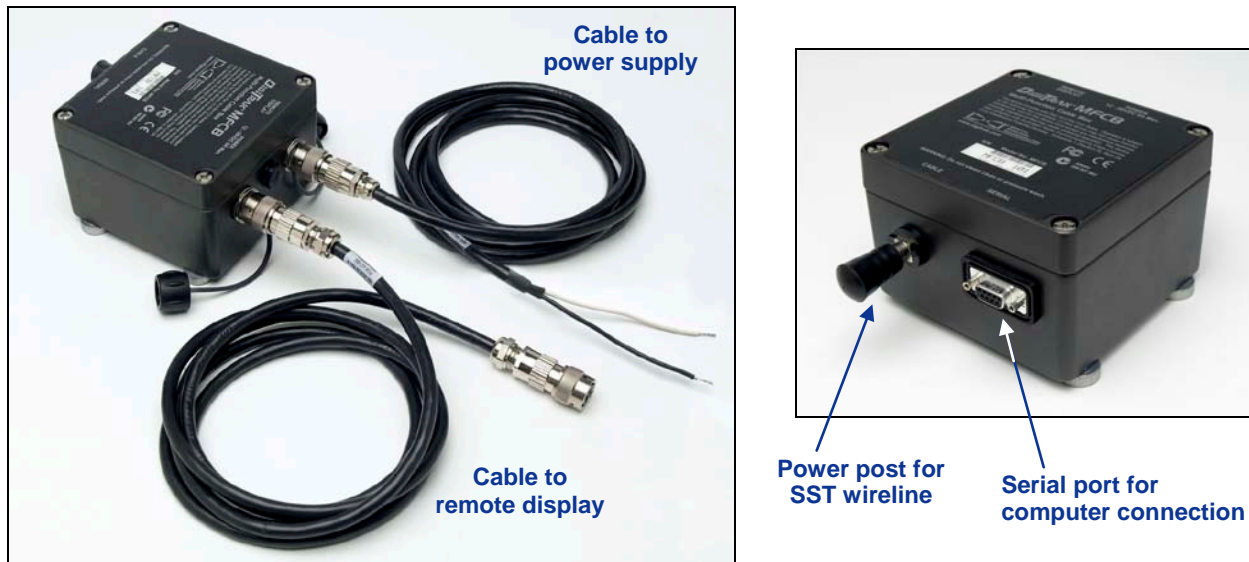

**Cable Box with Power Supply and Remote Display Cables**

A special power cable is provided for use with a panel-mounted MFD remote. This cable plugs into the back of the MFD and the other end connects to the cable box.

The white wire from the SST transmitter connects to the power post on the cable box. The laptop computer is connected to the serial port on the cable box. When connected, real-time data can be viewed at the computer, and data points can be logged by the computer operator. The SST software allows for viewing, logging, editing, graphing, saving, and printing of the drill data. See the *LWD Software Instructions* section for more information.



**Cable for Panel-Mounted MFD Remote**

Complete information and procedures for setting up the SST system and connecting the system components is given in the *System Operating Instructions* section.

## Laptop Computer with LWD Software

The F5 SST system comes with a dedicated laptop computer (PC) that has the LWD (Log-While-Drilling) software preinstalled. A 50-ft (15-m) long serial cable is provided for connecting the computer to the serial port on the cable box. A USB flash drive that contains the LWD software, this operator's manual, and sample data is also provided with the system.

The LWD software is used with other LWD applications; however, only the information that is pertinent to running the SST guidance system is included in this manual. Instructions for the other LWD applications are given in the *DigiTrak LWD DataLog System Operator's Manual*.

The steering application in the LWD software is used with the SST system. A typical steering job screen as it appears in the LWD application window is shown below. See the *LWD Software Instructions* and the *Inputting and Editing Drill Data* sections in this manual for more information about the software and how to use it.

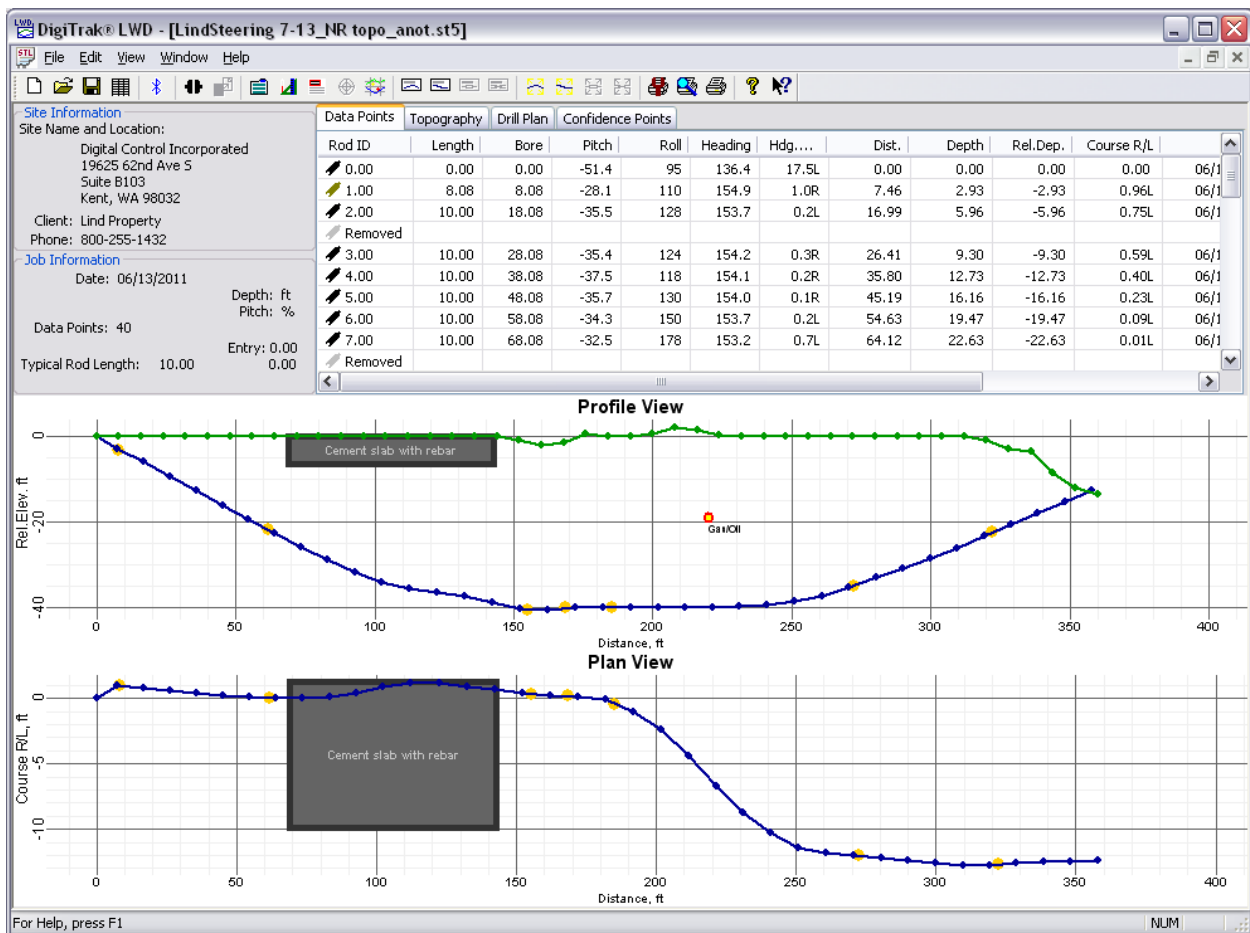

**LWD Steering Tool Application Window**

**NOTE:** Loading additional programs on the dedicated SST laptop could cause problems with the functioning of the LWD software.

### Non-DCI Components That Are Needed

Some equipment, tooling, and specialty items required for operation of the SST system are not supplied by DCI. These include the following:

- Non-magnetic housing for SST transmitter – Must be rear-loading with slots milled per the housing slot requirements discussed earlier in this section.
- Monel (non-magnetic drill rod) – A monel approximately 15-ft (4.6-m) long for use between the non-magnetic housing and the first drill rod; a second monel may be required if you are using a mud motor.
- Fish tape or device to fish wire through rod
- 10-gauge wire – Approximately 20 ft (6 m) for use as a ground connection when establishing the reference heading.
- 10-gauge wire – Enough for bore length and additional for pullback of rods.
- Butt splices for 10/12 gauge wire
- Heat shrinks
- Crimper
- Heat gun
- Transit or theodolite
- String for string line
- Tape measure
- 12–28V DC battery or power supply
- Amp meter
- Digital level
- Compression fitting – Required to seal the transmitter from drilling fluid; contact a drill or tooling manufacturer for information.

# System Operating Instructions

The SST guidance system provides information at the remote display and the computer that enables you to make accurate, reliable steering decisions. It also allows you to log and save the drill data.

This section provides detailed operating instructions for using the system. Please read the procedure carefully and ensure that you understand all the instructions before you use the system. Also, before you start to set up the system, be sure you have all the non-DCI components that you will need, as specified in the *System Components* section under “Non-DCI Components That Are Needed.”

The basic operating procedure includes the following general steps, which are detailed in this section:

- Setting Up SST Laptop
- Setting Up Equipment and Site
- Setting Reference Heading and Roll Offset
- Calibrating SST Transmitter and Confirming Proper System Operation
- Logging Drill Run

A summary of the procedure is provided at the end of the section.

## Setting Up SST Laptop

### 1. Plot Topography, Drill Plan, and Planned Deviation

Any topographic and/or planned bore information that you want in your SST job file can be input into the SST software before drilling or during the drilling/logging process. DCI recommends that you input this information before drilling unless you have a dedicated computer operator who can ensure correct and accurate input. Instructions for inputting data are provided in the *Inputting and Editing Drill Data* section.

## Setting Up Equipment and Site

### 2. Establish Bore Path Reference Line and Mark Bore Path

We recommend that you use surveying equipment to establish the bore path. Once, established, mark the bore path with a string line based off of the survey markers. This reference line will help in aligning the drill and non-mag tooling assembly to the intended bore path.

### 3. Assemble and Torque-up Non-Magnetic Housing to Non-Mag Tool

Using the drill rig or other hydraulic torquing wrenches, thread the non-mag housing to the non-mag tool and torque-up.

## 4. Align Drill to Marked Bore Path

With the transit positioned at least 10 ft (3 m) ahead of the drill, position the drill so that the transit sights onto the center point of the drive chuck and/or centerline of the boom. Anchor the drill, and then use the transit to confirm that the drill is still aligned to the marked bore path; if not, adjust for proper alignment.



*Aligning Drill to Marked Bore Path*

## 5. Position & Align Non-mag Tooling Assembly onto Marked Bore Path

With the transit still in position but rotated 180°, place the tooling assembly at least 30 ft (9 m) in front of the drill, onto the marked bore path so that it is pointing in the direction of drilling with the tool or bent sub oriented to 0° (12 o'clock), as shown in the photo on the right and the SST Job Site Setup diagram below. Sight the transit onto the string line (highlighted by yellow dashed line in photo) and carefully align the non-mag assembly to the marked bore path.

Be sure there are no large metallic objects, including the drill, within 30 ft (9 m) of the non-mag assembly.



*Aligning Non-Mag Tooling Assembly to Marked Bore Path*

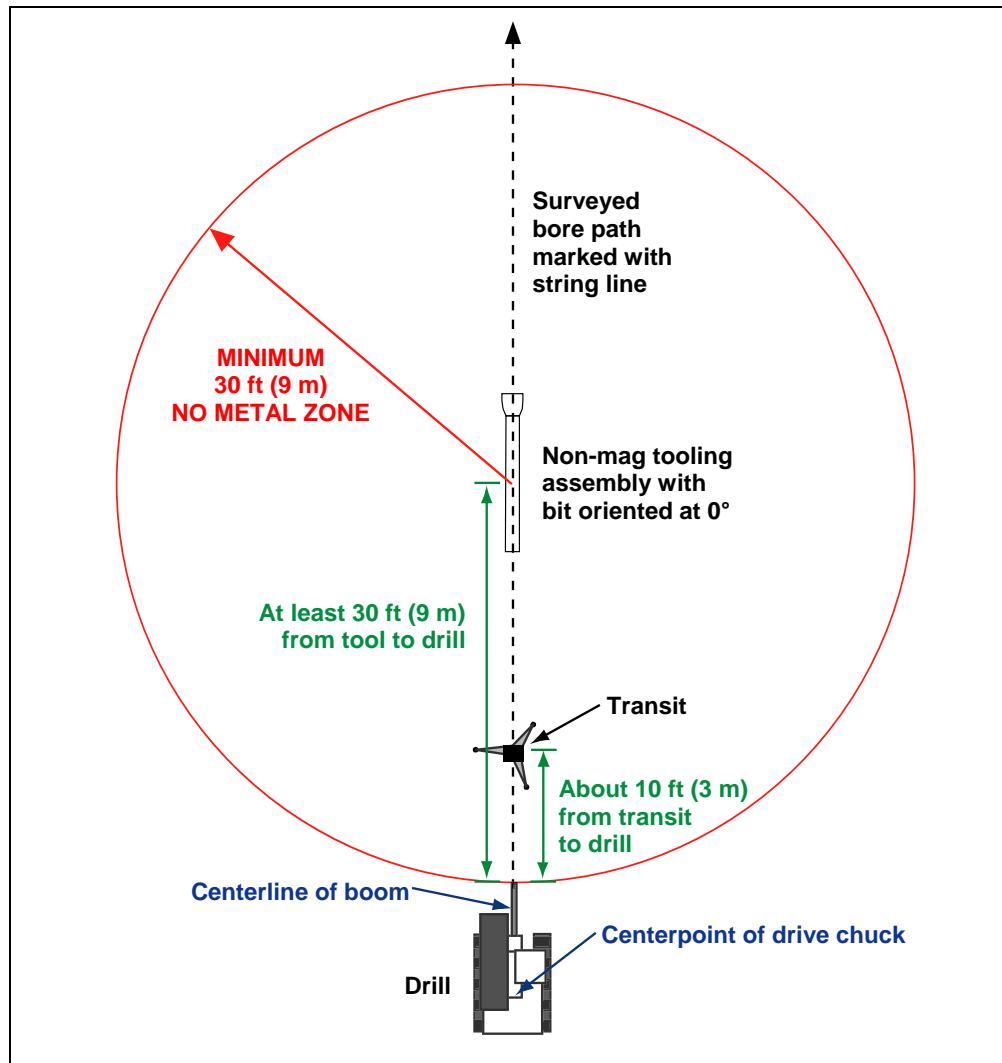

**SST Job Site Setup**

## 6. Stage SST Equipment and Power Source Adjacent to Tooling Assembly

In preparation for powering up the F5 SST equipment, position the following items adjacent to the tooling assembly, along with the required cords, cables, and supplies for connecting the components:

- F5 SST receiver and fully charged battery pack
- SST transmitter
- SST remote display (if using a panel-mounted MFD, remove it from the drill rig console; contact your dealer for assistance if necessary)
- Multi-function cable box (MFCB)
- Power source, such as a generator or 12–28V battery
- Amp meter

**NOTE:** Keep the remote display with its magnetic mounting bracket at least 5 ft (1.5 m) from the SST transmitter or damage to the SST transmitter could occur.

## 7. Connect and Power Up F5 SST Equipment

First, install the battery pack in the receiver, and then click the trigger to power it up. From the main menu, go to the transmitter selection menu and select the cable option, and then the SST transmitter option.

Next, connect the remote display to the cable box and the cable box to the power source, as shown in the following diagram. Then connect the SST transmitter to the amp meter and to the power post on the cable box. You must ground the transmitter by connecting the negative terminal on the power source to the metal end cap on the SST transmitter.

Press the execute button on the SST remote to power it up. From the main menu select the cable mode option and press the execute button to enter cable mode.

Verify that you see data on the remote display and the receiver. If you do not, then recheck your connections and try again or call DCI Customer Service for assistance.

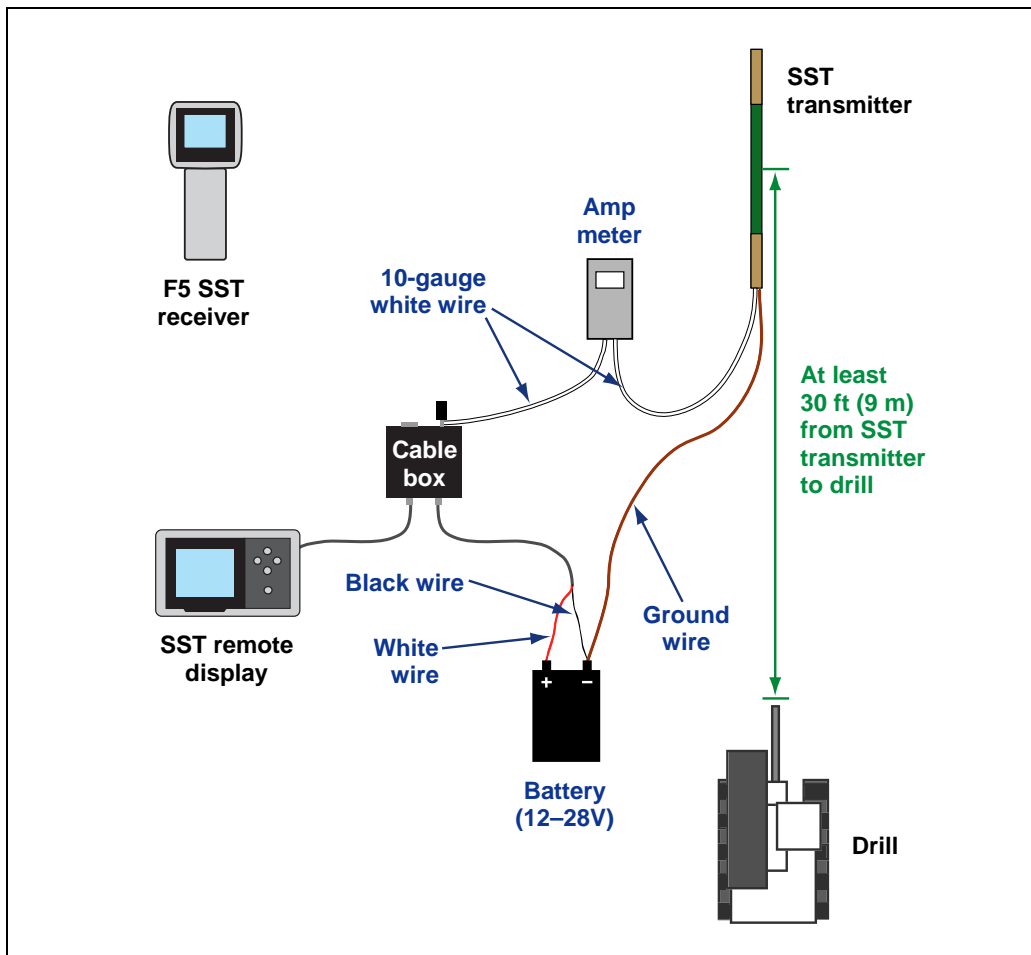

**Setup for S5T Transmitter Power Up and Amp Reading**

## 8. Measure SST Transmitter Current Draw

Using an amp meter hooked up in series as shown in the figure above, measure the current draw of the SST transmitter—a good reading is approximately 0.2 to 0.5 amp. The current draw will increase as the distance you drill increases. A normal current draw, for example, at 1500 ft (457 m) is about 0.7 amp. The maximum current draw you should see is approximately 1 amp.

## 9. Install SST Transmitter into Aligned Non-mag Tooling Assembly

To install the SST transmitter into the aligned non-mag housing (tooling assembly), first screw the threaded end of the extraction/insertion tool into one of the two threaded holes (1/4"-20 thread) in the wireline end of the transmitter. Then insert the front end of the transmitter into the back end of the housing and gently push it in using the extraction/insertion tool until you feel the index slot engage onto the housing key. When the transmitter is properly keyed, it will not rotate.

**NOTE:** Always use the extraction/insertion tool to install or remove the cable transmitter. Do not ever try to remove the transmitter from the housing by pulling on the transmitter wire.

Disconnect the amp meter, and reconnect the SST transmitter's wire to the power post on the cable box. Be sure to ground the housing; this is commonly done by cutting a length of wire and touching one end to a negative battery terminal and the other end to the non-mag housing.

## Setting Reference Heading and Roll Offset

### 10. Set Reference Heading – Shoot the Probe

Press the up button on the front of the remote display from the cable mode screen to open the reference heading popup menu. The current heading (Heading) of the SST transmitter, which in our case is the reference heading (Ref Heading) of the intended bore path, will display in the "Set" option box in the popup menu. In the example shown below, the reference heading of the intended bore path and the heading of the transmitter are both 339.2°. The receiver's locate mode screen also displays the heading of the SST transmitter.

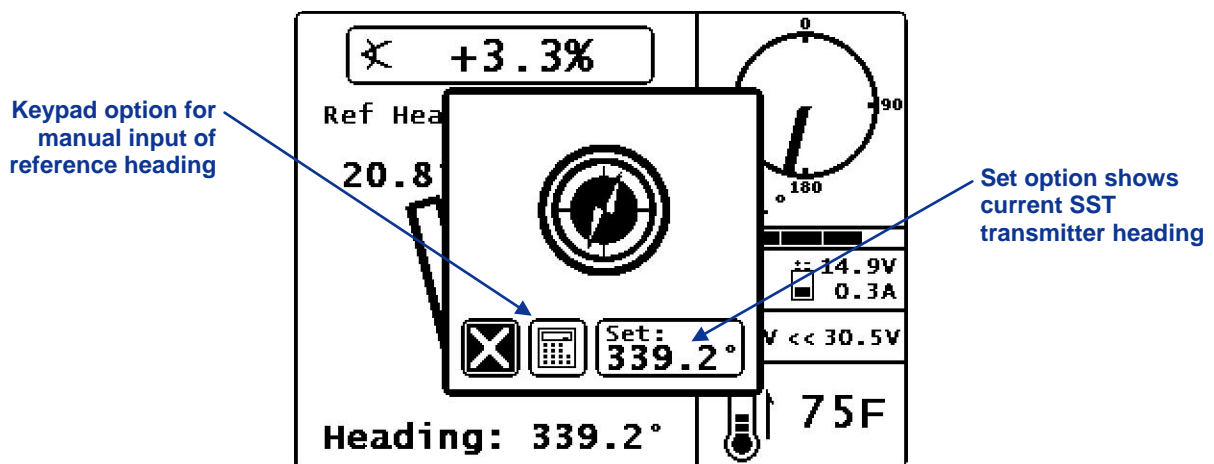

*SST Remote Popup Menu for Establishing Reference Heading*

Write down this value (the current heading shown in the set option box) as your reference heading for future use. To accept this value, push the right arrow button to highlight the set option, and then push the execute button. If the reference heading is to be entered manually, use the keypad option to enter the desired value.

With the reference heading and SST transmitter heading the same, the reference heading value at the top of the remote display screen should match the heading value at the bottom of the screen, as shown below. The reference heading and heading are also graphically displayed by a dashed vertical line with an arrowhead and a tool icon (a long rectangular box) representing the SST transmitter, respectively.

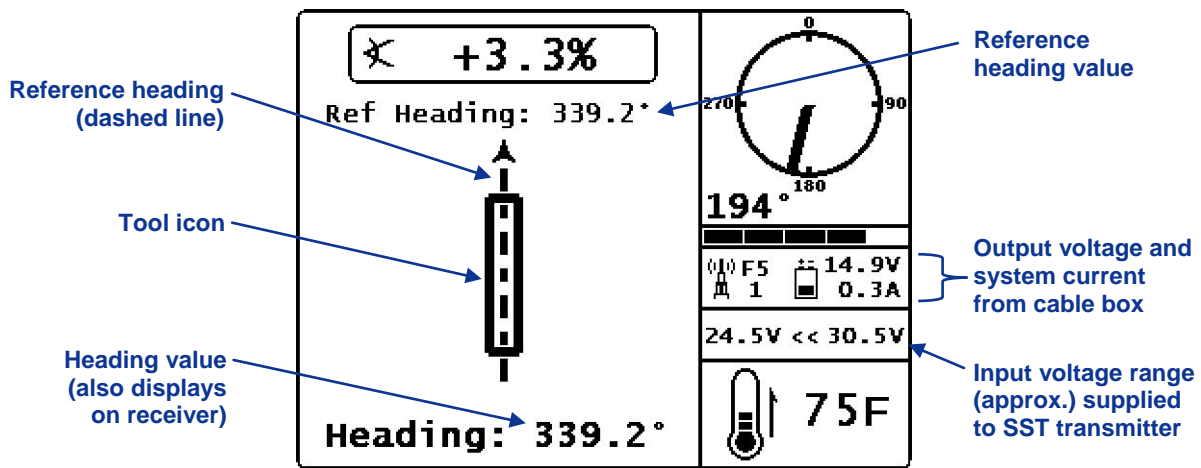

**SST Remote Steering Screen Showing New Reference Heading**

**NOTE:** If possible, take a heading reading at several locations along the bore path. This will allow you to determine an average reference heading to use over the bore path and possibly identify variations in the heading that could result in inaccurate readings.

When the SST transmitter's heading does not match the reference heading, the tool icon will be to the left or right of the dashed line, and a corresponding value will display above the tool icon to indicate the number of degrees that the SST transmitter is off from the reference heading, as shown below.

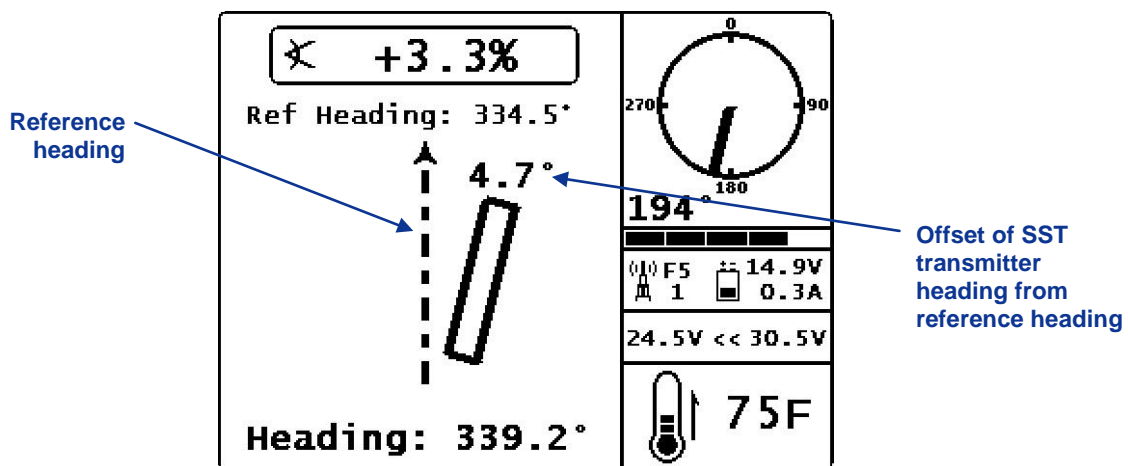

**SST Remote Steering Screen Showing Heading 4.7° to Right of Reference Heading**

## 11. Set Roll Offset on Remote (if needed)

If the SST transmitter's 0° roll position does not match the bit's 0° roll position, then the roll offset function must be used to electronically compensate for the difference. The roll offset function must be set or enabled on both the remote display and the receiver. Before setting the roll offset, position the drill head in a 0° roll orientation.

To set the roll offset on the remote display, push the right arrow button from the steering screen. A popup menu will display to set a new roll offset, with the option to set the displayed value or exit.

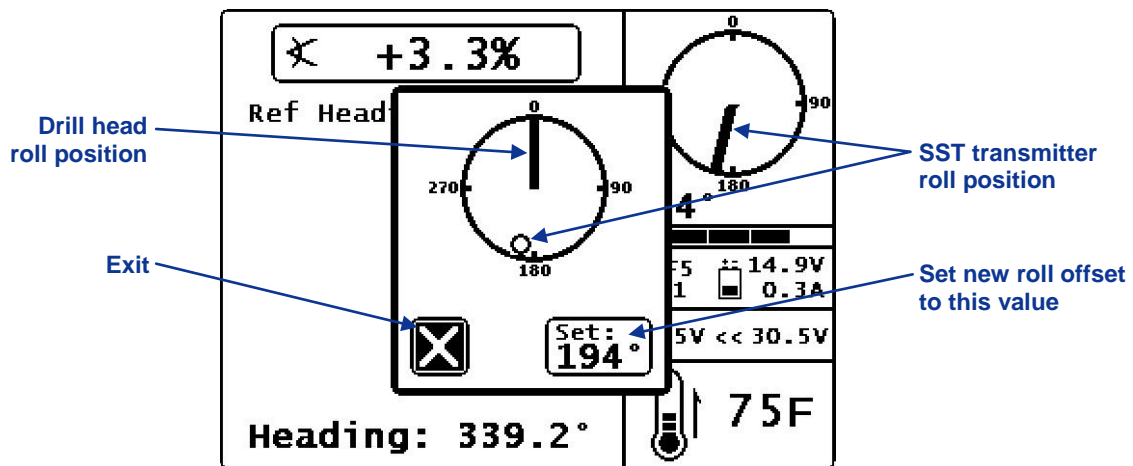

**SST Remote Popup Menu for Setting New Roll Offset**

Push the right arrow button to highlight the set option and press the execute button. The roll position and roll value on the remote will change to read 0°, and the roll offset value (194° in this example) will appear below the letters "RO" on the lower right of the roll indicator, as shown below.

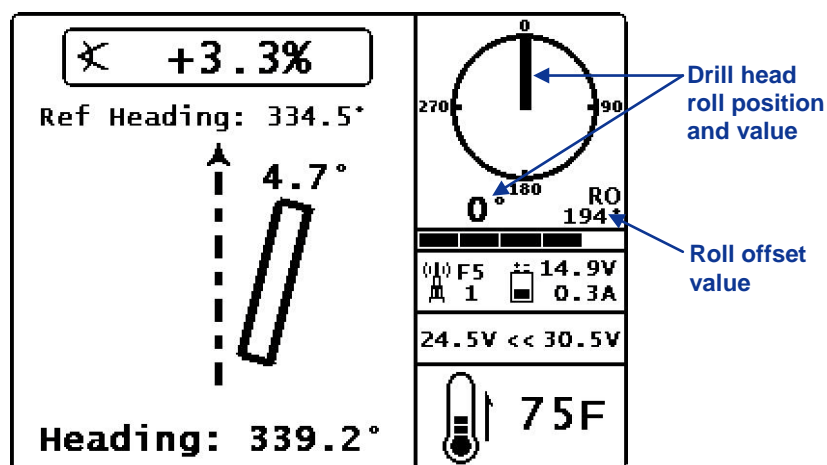

**SST Remote Steering Screen Showing New Roll Offset Value**

To stop the roll offset function or change the roll offset value, push the right arrow button when at the steering screen to open the popup menu shown below. Toggle right to highlight the stop or set option, and then press the execute button.

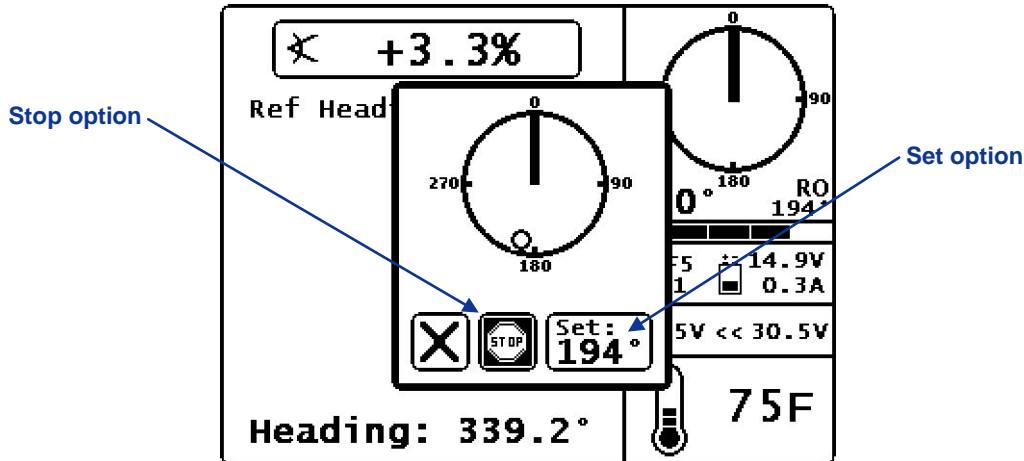

**SST Remote Popup Menu for Stopping or Changing Roll Offset**

If the stop option is selected, the roll offset function will be turned off and the value of the roll shown on the remote display will be that of the SST transmitter. If the set option is selected, the roll offset function will be enabled with the roll offset value shown.

## 12. Set Roll Offset on Receiver (if needed)

If you have set the roll offset function on the remote, then you must next set and enable the function on the receiver. First, select the roll offset option from the settings menu on the receiver. The roll offset menu will display, as shown below.

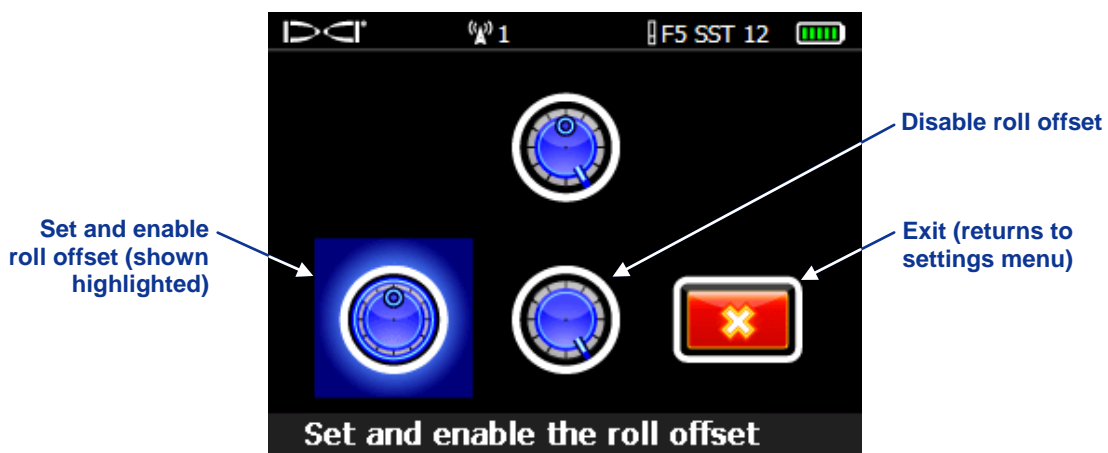

**SST Receiver Roll Offset Menu**

Select the set and enable roll offset option, and the following screen will display.

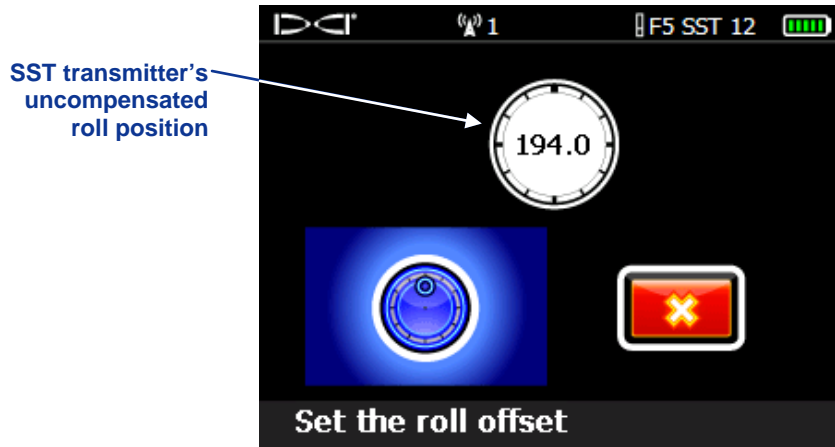

**SST Receiver Enable Roll Offset Menu**

Click the trigger to set the roll offset to the value displayed. The display will return to the locate mode screen with the roll offset enabled as indicated by the roll value being 0.0 and the letters "RO" appearing to the lower left of the roll indicator.

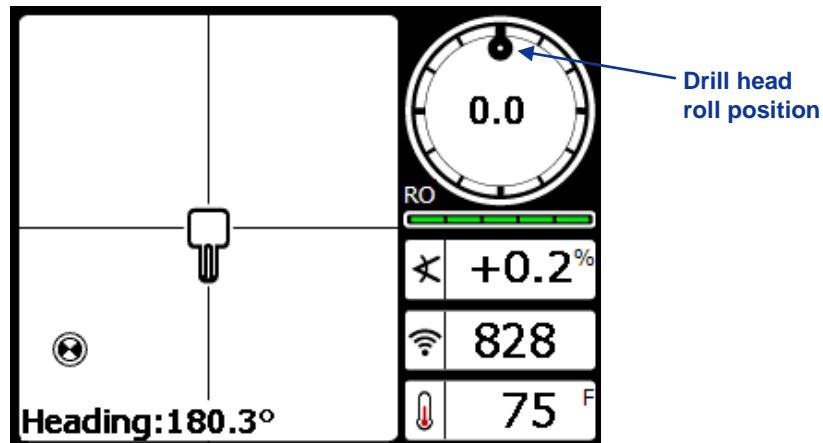

**SST Receiver Locate Mode Screen Showing New Roll Offset**

To disable and stop the roll offset function, select the roll offset option from the settings menu, then toggle right to highlight the option to disable the roll offset and click the trigger. The roll offset function will be disabled and the value of the roll shown on the receiver will be that of the SST transmitter.

## Calibrating SST Transmitter and Confirming Proper System Operation

### 13. Calibrate SST Transmitter to Receiver

In this step, you will use the receiver to conduct a 1-point calibration (10 ft or 3 m), and then you will verify accurate depth readings using a tape measure.

First, ensure that there are no metal structures within 30 ft (9 m), such as steel pipe, chain-link fence, metal siding, construction equipment, or automobiles. Also make sure that the receiver is not positioned over rebar or underground utilities. Check signal strength by selecting the locate mode from the receiver's main menu screen. Position the receiver 10 ft (3 m) to the side of the SST transmitter in the non-mag housing, as shown in the figure below.

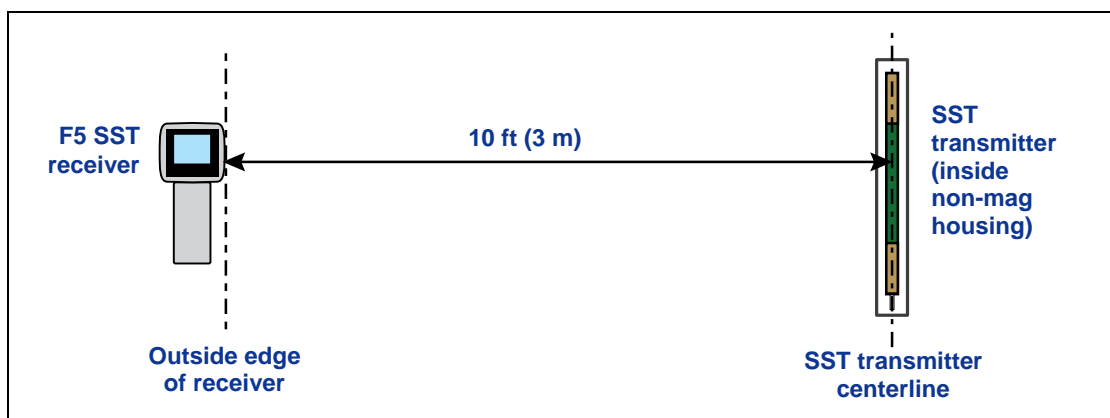

**10-Foot (3-m) Measurement for Calibration Procedure**

Verify that the signal strength at this distance is 660 to 680. Return to the main menu screen (toggle down once). Select the calibration option from the main menu screen and click the trigger. Select 1-point calibration and follow the prompts to complete the calibration. Do not move the receiver while it is calibrating.

When calibration is complete, the confirmation signal will sound and a checkmark will display on the screen, indicating a successful calibration. The screen will then return to the locate mode display. Take depth readings at several locations using a tape measure to verify that the depth reading on the display remains accurate.

### 14. Measure SST Transmitter Current Draw in Housing

Using an amp meter hooked up in series, as shown in the figure in step 7 entitled “Setup for SST Transmitter Power Up and Amp Reading,” measure the current draw of the SST transmitter—a good reading is approximately 0.2 to 0.5 amp.

### 15. Verify Pitch Readings Using Digital Level

Compare the SST transmitter's pitch readings at the remote display and the receiver with those shown on a digital level. Position the digital level on the housing, and then lift or lower the housing to different inclinations and compare the readings on the level against the pitch readings on the remote and the receiver to confirm accuracy.

## 16. Connect SST Equipment to the Drill

You are now ready to connect the 10-gauge white wire from the SST transmitter to the monel's 10-gauge wire with a butt splice and heat shrink. The monel is a non-mag drill pipe that measures approximately 15 ft (4.6 m) in length and must be used between the non-mag housing and the regular drill pipe. Once this wire connection is made, the housing can be threaded onto the monel while carefully pulling the slack in the wire to ensure that the wire does not get caught in the threads. You will continue to thread the wireline through the drill rods in the same manner, carefully making the connection for each drill pipe.

The following diagram shows how the SST system components are connected. A ground wire needs to be installed between the negative terminal of the free-standing battery and a ground point on the drill rig. The ground point can be the negative terminal on the drill rig's battery or a metal contact point on the drill rig or drill stem.

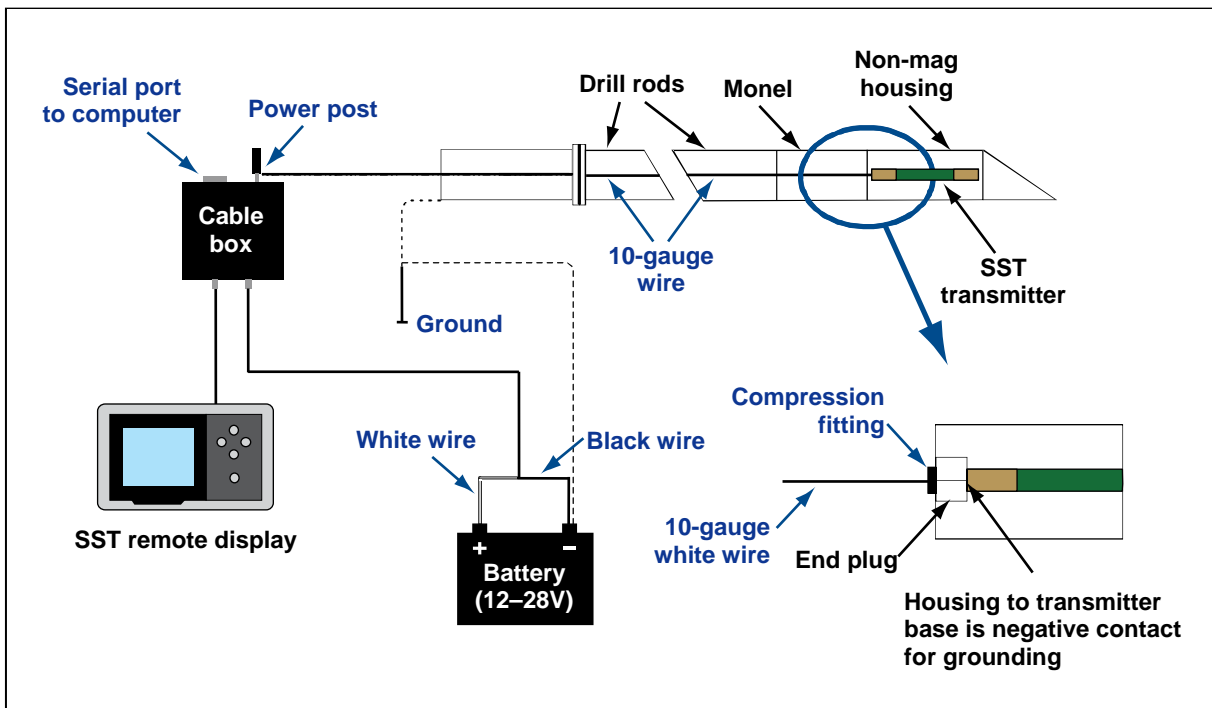

### Connecting SST System Components

The compression fitting shown in the diagram is a non-DCI part required to seal the transmitter from the drilling fluid. Contact a drill or tooling manufacturer for information on compression fittings.

With the SST transmitter properly grounded through the drill housing, connect the wire from the transmitter and now exiting the drill string to the power post on the cable box. Rotate the knob on the power post counterclockwise until the hole in the post is exposed. Insert the stripped portion of the wire into the hole and gently tighten the knob.

Connect the cable box to the serial port on the laptop computer using the serial cable provided with the system. The laptop can be positioned as far as 50 ft (15 m) from the drill.

## 17. Start LWD Program and Confirm System Operation

Power up the laptop and then start the LWD program (see *LWD Software Instructions* section). Select **File | New** or click on the new file icon on the tool bar, and then select the “Steering” option to open a new steering file. The Steering Tool Job Information dialog box will appear before the new file opens.

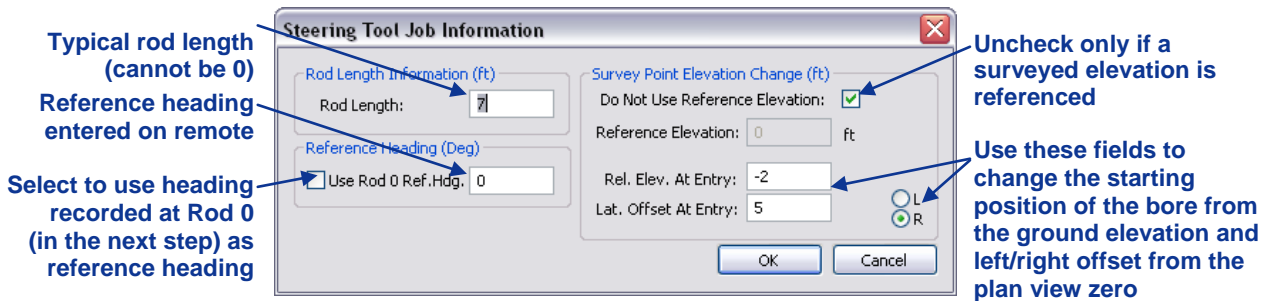

**Steering Tool Job Information Dialog Box**

Enter the requested information; this information can be edited at anytime by selecting **Edit | Job Information** or clicking the edit job information icon . Click on OK to open the new steering tool job file in the LWD application.

Select **File | Upload Control...** or click on the upload control icon on the toolbar to open the Steering Tool Data Upload Control dialog box shown below.

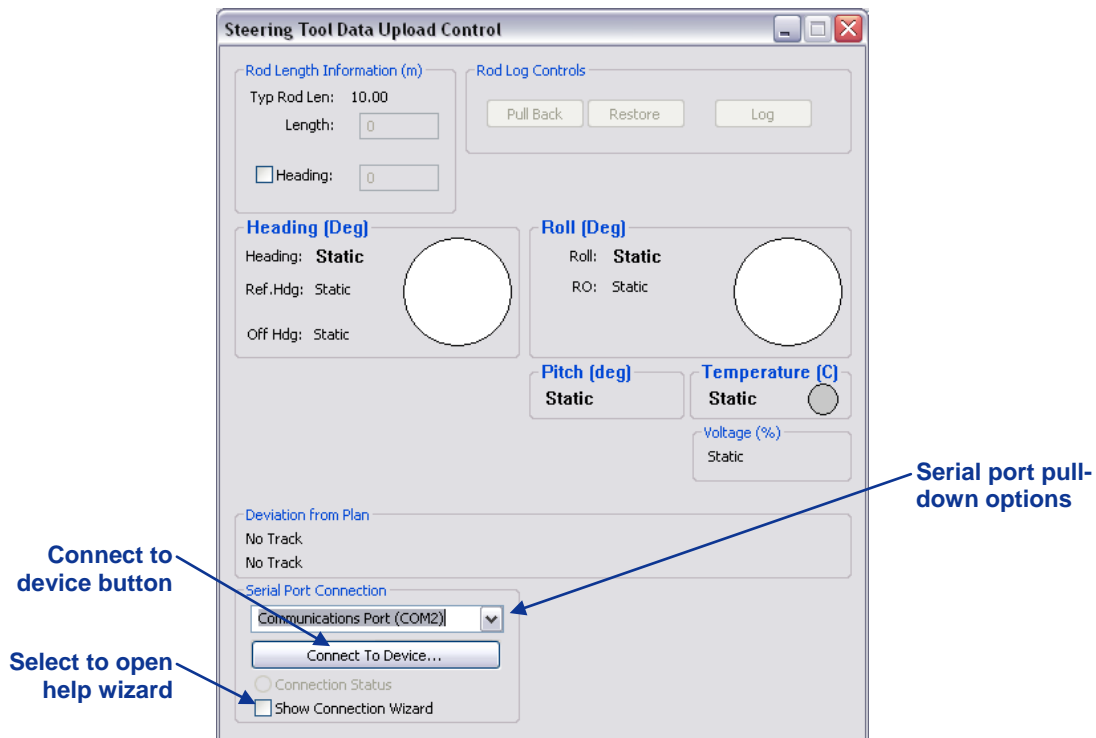

**Steering Tool Data Upload Control Dialog Box (not connected)**

Using the pull-down menu under Serial Port Connection, select Communications Port (COM1), and then click on the connect button below to connect to the cable box. Verify that you see live data, as shown in the dialog box below. If you do not, then verify the setup and port selection and try again.

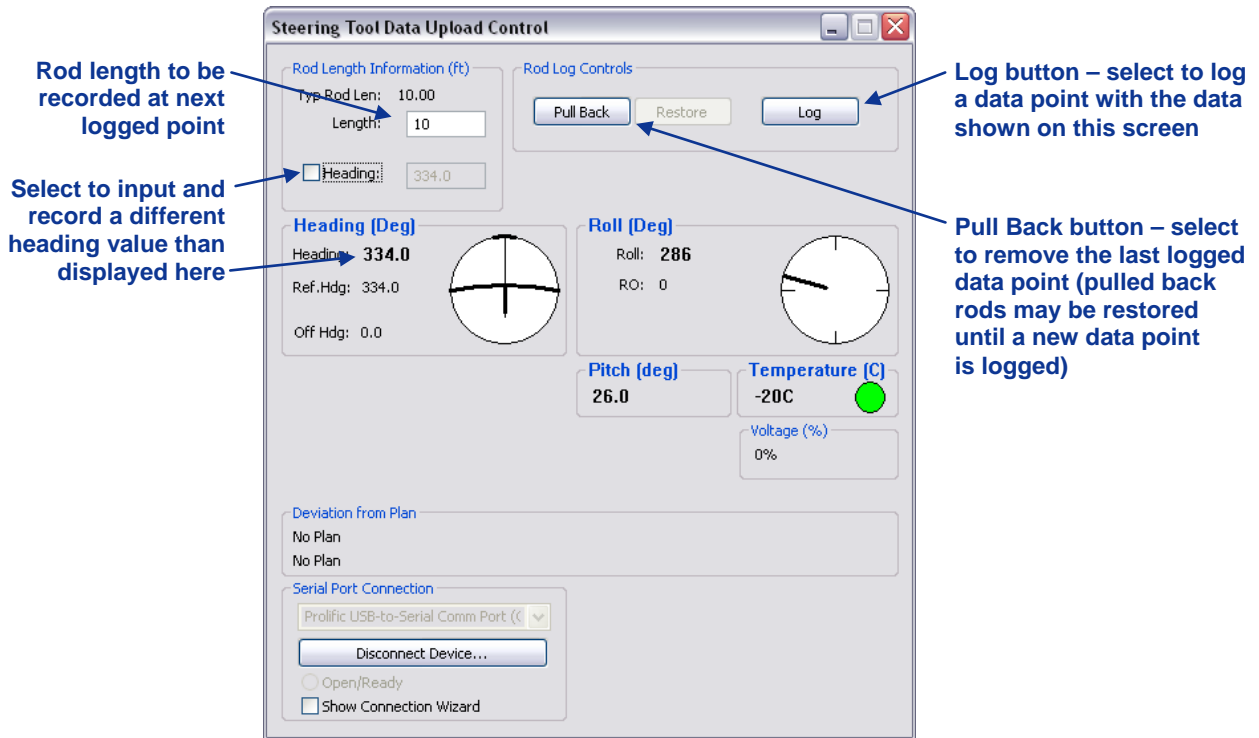

**Steering Tool Data Upload Control Dialog Box (connected)**

See the *Inputting and Editing Drill Data* section later in this manual for complete information on using the job information and data upload control dialog boxes.

## Logging Drill Run

### 18. Log Rod 0 (zero)

The first logged point should be recorded when the SST transmitter (in its non-mag housing) is positioned so that it is  $\frac{1}{2}$  in and  $\frac{1}{2}$  out of the ground, as shown in the following diagram.

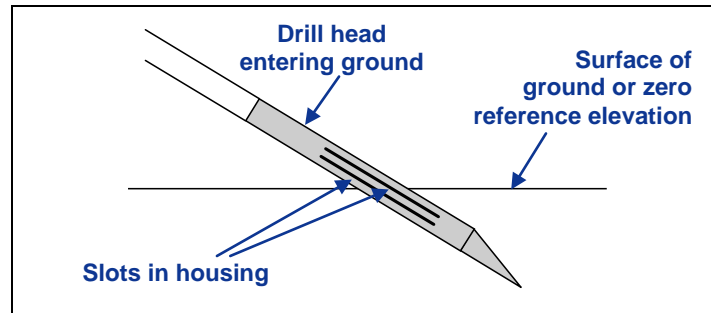

**Tooling Position for First Logged Point**

Once the tool is in position, then click on the Log button in the upper right of the Steering Tool Data Upload Control dialog box to log a point. This logged point starts the zero reference of the bore.

If entry is into a pit, measure the difference in depth between the surface of the ground and the center of the slots in the housing. Enter this depth value as the "Rel. Elev. At Entry" in the Steering Tool Job Information dialog box.

### 19. Locate (if possible), Override Data (if necessary), and Continue to Log

As the tool moves away from the drill, to maintain a straight drill path the heading readings should match the reference heading. Based on your steering commands and the tool's located position (using the receiver), you can determine if the heading and pitch are correct or if compensation in the LWD log is required. Be sure to wait a few seconds for all readings to stabilize before pressing the Log button. If the heading value is incorrect, it can be edited in the Steering Tool Data Upload Control dialog box before logging the rod to override the measured value. It can also be edited after logging by using the Edit Steering Tool Data Point dialog box described below. See the *Inputting and Editing Drill Data* section for more information.

## 20. Compensate for Differences Between Tool's Logged Position Data and Tracked Position

Differences between the computer's calculated position and the tool's tracked position can occur if the first point was not logged when the SST transmitter was ½ in and ½ out of the ground, such as when using a mud motor, or in cases where the heading measured by the SST transmitter has natural variations over the bore path, as determined during a pre-bore walkover. In such cases, it may be necessary to compensate by changing the pitch reading, heading, or rod length.

To modify these values, place your mouse on the row of data to be edited in the data points table in the main application window, and double-click to open the Edit Steering Tool Data Point dialog box (see figure below). Note that, if you make a change to the data, the rod number for that row will show a gray rod as opposed to black for an unmodified data point and it will be highlighted on the data chart.



**Edit Steering Tool Data Point Dialog Box**

Depth values that are calculated in the LWD software can only be edited by changing these input values.

To adjust the recorded bore path based on externally measured data, use the confidence points tab in the data tables area of the main application window. Topography must be input in order to use confidence points. See the *Inputting and Editing Drill Data* section for more information.

## 21. Pull Back Rods, Resteer, and Relog

If it is necessary to pull back and resteer the tool, you will use the control buttons (Pull Back, Restore, and Log) under Rod Log Controls in the Steering Tool Data Upload Control dialog box.

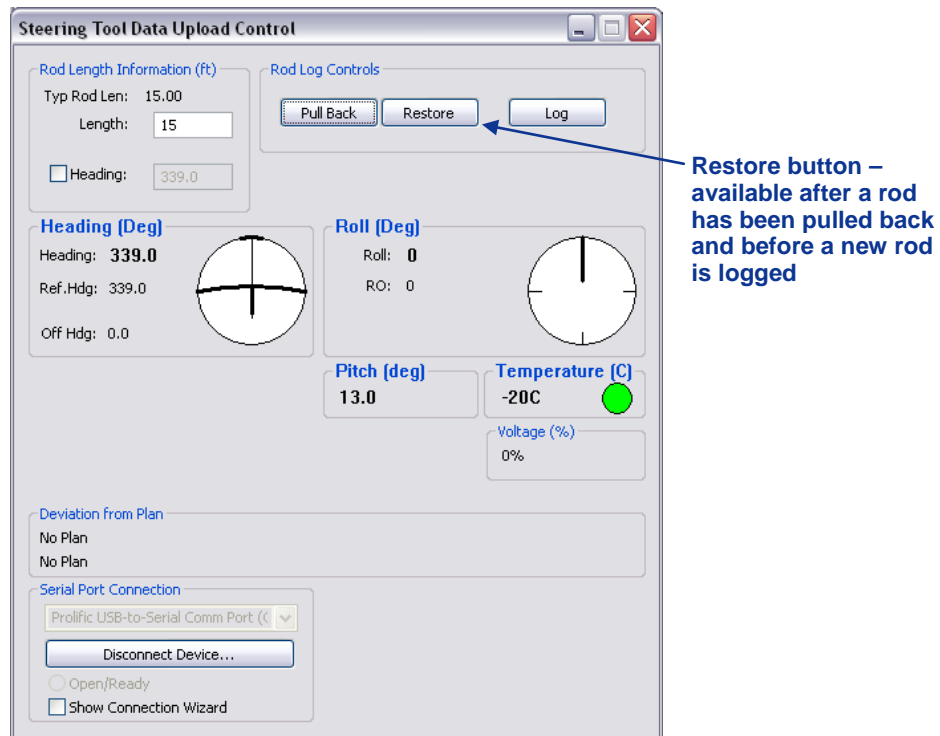

**Steering Tool Data Upload Control Dialog Box (pull back)**

Every time you click the Pull Back button, you will remove the data for the last logged data point from the profile and plan view plots and also from the data points table (see *LWD Software Instructions* section). If you decide to not pull back after you have retreated rods, you can press the Restore button until you are back to the original position or where you want to start resteeing, and the original data will reappear. Once a rod is pulled back it will remain visible on the screen until a new rod that changes the previous bore path is logged.

**NOTE:** Be careful to be methodical when pulling back and advancing rods so that you do not hit the button more times than the number of rods pulled back or advanced.

## 22. Save Drill Data Occasionally

DCI recommends that you save the drill data periodically during the bore. A suggestion is to include the name of the project, the horizontal distance from the launch point ("Dist." column in data points table), and the LWD software version in the filename. For example, for a job where Pole Road is the name of the project, 880 feet is the x-distance from the launch point, and the LWD software version is 2.04, an appropriate filename would be "Pole Road 880 v2.04".

## 23. Log Last Rod

The last rod logged is just as important as the first. At the end of the run, with the tool at the exit location, you must measure the length of the last rod and input the length in the Rod Length Information area of the Steering Tool Data Upload Control dialog box before logging the data point. The last rod measurement is the rod length minus the length of drill rod left on the rack. For example, if you measure 6 ft (1.8 m) from the make-up/break-out clamps to the top of the rod, then you would subtract 6 ft (1.8 m) from the rod length. If the rod length is 10 ft (3.0 m), then the last rod measurement will be 4 ft (1.2 m).

**NOTE:** If the depth of the last rod is less than 24 in. (61 cm) and you are tracking the SST transmitter with the receiver, you must set the height-above-ground (HAG) measurement and log the last data point above the ground level for an accurate depth reading, or you can record a pitch-only data point.

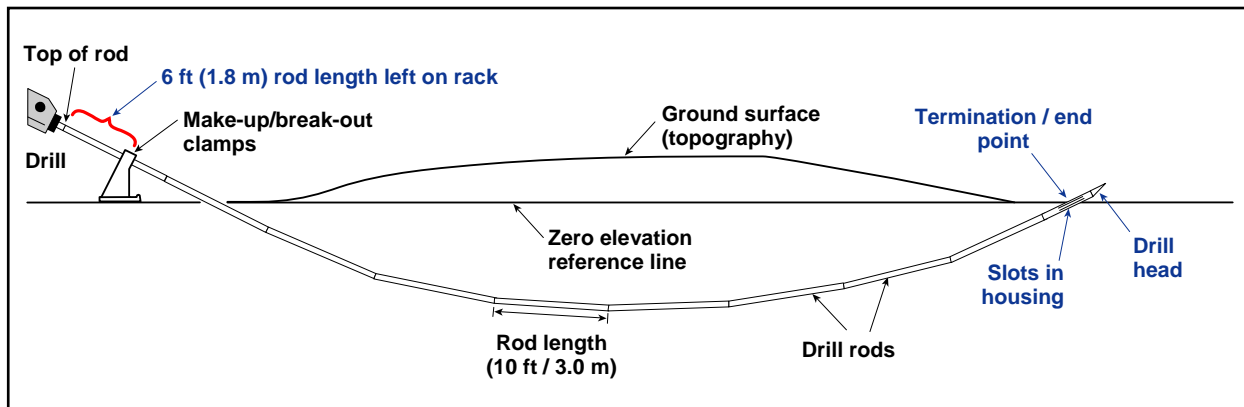

### Last Rod Measurement

Press the Log button after modifying the rod length to the last rod measurement value.

## 24. Save Project

DCI recommends that you save the project at the end of the bore using at least two different names, which will provide an extra copy of the data for backup. Then, if you accidentally make changes you don't want, you can still revert to the earlier version of the file. You may even want to save the drill data more than two times.

## Summary of Basic Operating Procedure



- Setting Up SST Laptop
  1. Plot topography, drill plan, and planned deviation.
- Setting Up Equipment and Site
  2. Establish bore path reference line and mark bore path.
  3. Assemble and torque up non-magnetic housing to non-mag tool.
  4. Align drill to marked bore path.
  5. Position and align non-mag tooling assembly onto marked bore path.
  6. Stage SST equipment and power source adjacent to tooling assembly.
  7. Connect and power up F5 SST equipment.
  8. Measure SST transmitter current draw.
  9. Install SST transmitter into aligned non-mag tooling assembly.
- Setting Reference Heading and Roll Offset
  10. Set reference heading and shoot the probe.
  11. Set roll offset on remote display (if needed).
  12. Set roll offset on receiver (if needed).
- Calibrating SST Transmitter and Confirming Proper System Operation
  13. Calibrate SST transmitter to receiver.
  14. Measure SST transmitter current draw in housing.
  15. Verify pitch readings using digital level.
  16. Connect SST equipment to the drill.
  17. Start LWD program and confirm system operation.
- Logging Drill Run
  18. Log Rod 0 (zero).
  19. Locate (if possible), override data (if necessary), and continue to log.
  20. Compensate for differences between tool's logged position data and tracked position.
  21. Pull back rods, resteer, and relog.
  22. Save drill data occasionally.
  23. Log last rod.
  24. Save project.

# LWD Software Instructions

## Starting LWD Program and Opening Files

The LWD (Log-While-Drilling) software, which is preinstalled on the SST laptop computer, is used with the F5 SST guidance system. The SST transmitter is referred to as the “steering tool” in the LWD software.

There are three ways to start the DigiTrak LWD program:

- Double-click on the LWD icon  on the desktop.
- Use the Start button and select **Start | All Programs | Digital Control, Inc | DigiTrakLWD |  DigiTrakLWD.**
- From Windows Explorer, double-click on the DigiTrakLWD.exe file in the C:\Program Files\DCI\DigiTrakLWD folder, or the folder you have designated for the storage location.

After you start up the program, use the **File | New** command on the menu bar or click on the new file icon  on the tool bar then select the “Steering” option to open a new steering file. You will be prompted to enter values for the rod length and reference heading before continuing. The rod length may be any value other than zero; the reference heading may be any value from 0 to 360. If no reference heading is entered, the reference heading used in the file will be that recorded at the first data point (Rod 0). Click on OK to open a blank steering tool file, as shown below.

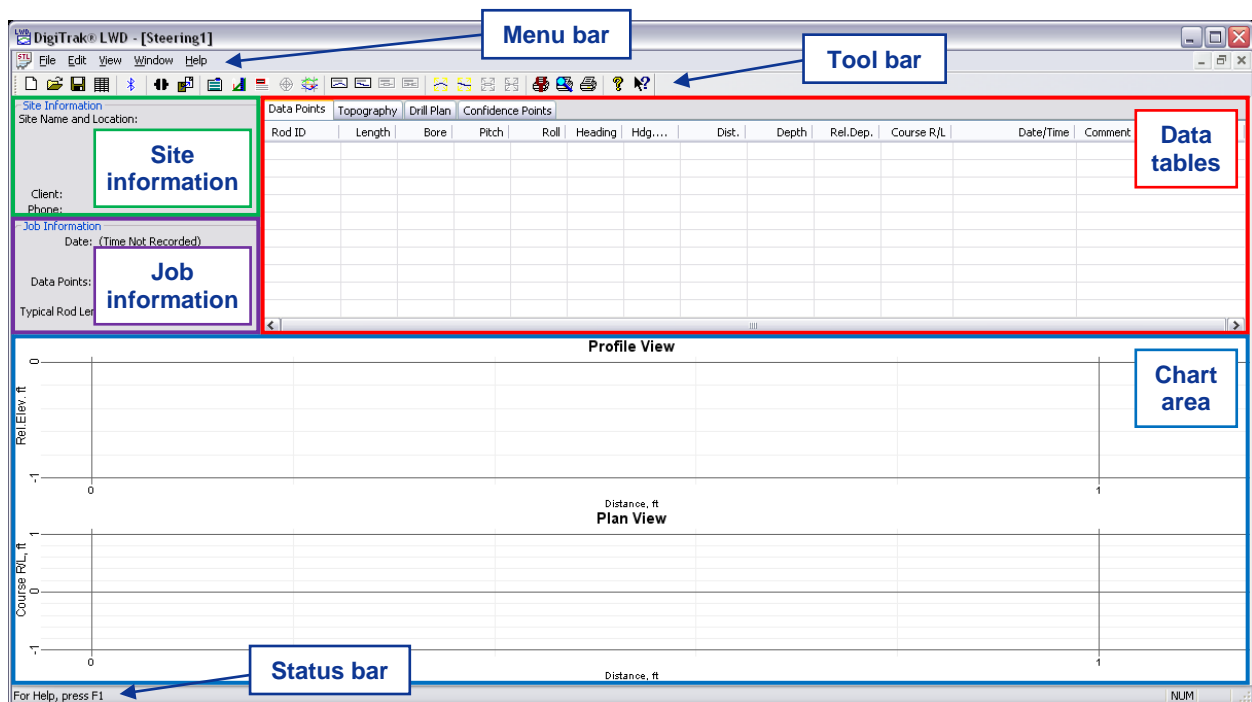

*LWD Steering Tool Application Window (without data)*

To open an existing steering file, use the **File | Open** command (or the file open icon ). You can also open a steering file directly from Windows Explorer. The file extension for a steering file is \*.st5. When a file is opened, the data information fields and charts are filled with data, as shown below.

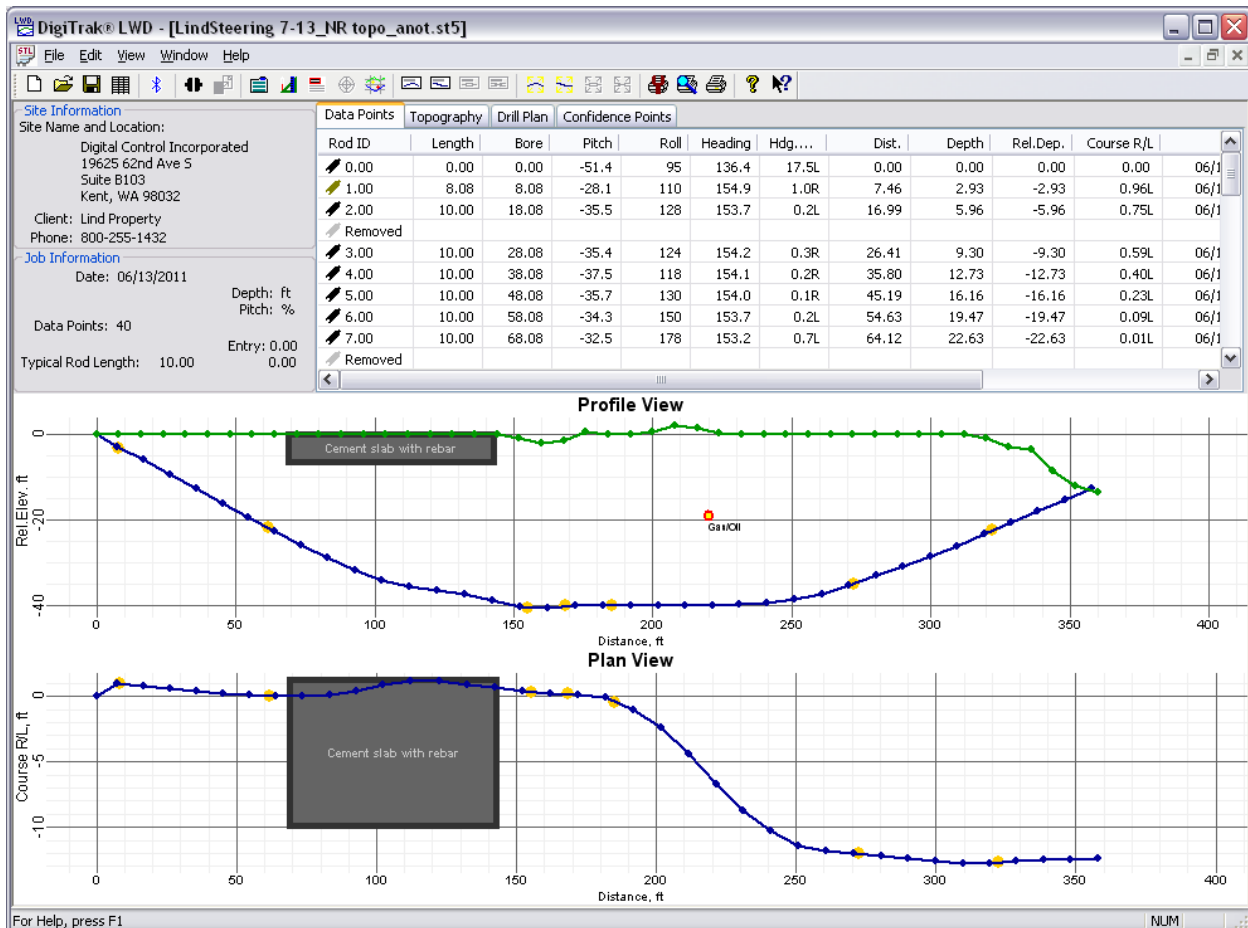

**LWD Steering Tool Application Window (with data)**









The LWD application menus and tool bar icons are described in the following subsection, and the different information fields (site information, job information, data tables, and profile and plan view charts) are described afterward.

We recommend that you review the help files in the LWD software for more information. The tool tip helper can also be used to understand different parts of the application window and file. Click on the tool tip helper icon on the tool bar and click on a point of interest within the file to open a help window with information about the point of interest.









## Menu and Tool Bars

Under each menu item on the menu bar (**File**, **Edit**, **View**, **Window**, and **Help**) are commands for running the LWD program. Many of the commands are similar to those used in other Windows programs and have associated icons on the tool bar. The menu commands and associated tool bar icons are summarized below. You can also move the cursor over any icon on the screen for a brief description of its function.

### File Menu Commands

|                              |   |  |
|------------------------------|---|--|
| <b>New</b>                   |    | Opens the New dialog box where you select the job type to be created ("Steering" for an SST or steering tool job). Once a selection is made, a new blank job screen appears.   |
| <b>Open...</b>               |    | Allows you to select an existing project to open from a Windows Explorer dialog box.   |
| <b>Save</b>                  |    | Saves an open project using the same file name and folder as designated previously.  |
| <b>Save As...</b>            |   | Opens the Save As dialog box to save the open job to a specified file name and folder. When a new file has not yet been saved, selecting the save icon on the tool bar will open the same screen as the Save As menu command. NOTE: DCI recommends saving SST data often and with different names. |
| <b>Print...</b>              |   | Opens the Print dialog box where you can select printing options and print the job.  |
| <b>Print Preview...</b>      |  | Displays the project on the screen as it would appear printed.   |
| <b>Print Setup</b>           |  | Allows you to select a printer and printer connection as well as the paper size and orientation.   |
| <b>Import</b>                |   | Allows you to import data saved using the Atlas Bore Planner or terrain or drill plan data that you have saved as a comma-separated-value (CSV) file.  |
| <b>Export Spreadsheet...</b> |  | Exports a spreadsheet-compatible CSV (*.csv) Unicode text file so you can share charts using standard spreadsheet software.  |
| <b>Upload Control...</b>     |  | Launches or hides the Steering Tool Data Upload Control dialog box where you can link to the cable box and view and record steering tool data.   |
| <b>File 1, 2...</b>          |   | Opens the specified previously opened file.  |
| <b>Exit</b>                  |   | Exits DigiTrak LWD program.  |

## Edit Menu Commands

|                                     |   |   |
|-------------------------------------|---|---|
| <b>Site Information...</b>          |    | Opens the Site Information dialog box where you can enter and edit the location and contact information that displays in the site information field in the upper left corner of the application window. General comments about the job may also be entered in the Site Information dialog box. This dialog box can also be accessed by double-clicking in the site information field of the application window. |
| <b>Display Units...</b>             |    | Opens the Display Units dialog box where you can select the depth, pitch, temperature, and force/pressure units displayed on the charts in the application window. The Set Defaults option in this dialog box will force all future files that are opened to use the same setting.  |
| <b>Job Information...</b>           |    | Opens the Steering Tool Job Information dialog box where you can edit details associated with the steering job such as the average rod length and reference heading used during the bore. A reference elevation and offsets for the accurate graphing of data may also be entered here. This dialog box automatically launches after a new job is created.  |
| <b>Utilities...</b>                 |    | Opens the Utility Flags dialog box where you can add, change, or delete flags and data regarding utilities.   |
| <b>Profile Chart Annotations...</b> |    | Opens the Steering DataLog Profile Annotations dialog box where you can make comments and insert drawings to appear on the profile chart. This dialog box can also be opened by holding the shift key down and using the mouse button to draw a box in the profile chart area.  |
| <b>Plan Chart Annotations...</b>    |  | Opens the Steering DataLog Plan Annotations dialog box where you can make comments and insert drawings to appear on the plan view chart. This dialog box can also be opened by holding the shift key down and using the mouse button to draw a box in the plan view chart area.   |
| <b>Profile Chart Properties...</b>  |  | Opens the Profile Chart Extents and Mode dialog box where you can adjust the scaling of the profile chart.  |
| <b>Plan Chart Properties...</b>     |  | Opens the Plan Chart Extents and Mode dialog box where you can adjust the scaling of the plan chart.  |

Some of the icons on the tool bar that are associated with the **Edit** menu are not available (grayed out) because they pertain to other LWD applications, such as the Pressure-Tension and the Drill DataLog applications.

## View Menu Commands

|                                 |   |   |
|---------------------------------|---|---|
| <b>Toolbar</b>                  |   | Shows or hides the tool bar.                  |
| <b>Status Bar</b>               |   | Shows or hides the status bar.                |
| <b>Bluetooth Device List...</b> |  | Shows a list of registered Bluetooth devices. |

## Window Menu Commands

|                       |  |  |
|-----------------------|--|--|
| <b>New Window</b>     |  | Opens the current file in a new window.    |
| <b>Cascade</b>        |  | Arranges windows in an overlapped fashion. |
| <b>Tile</b>           |  | Arranges windows in non-overlapped tiles.  |
| <b>Arrange Icons</b>  |  | Arranges icons of minimized windows.       |
| <b>Window 1, 2...</b> |  | Goes to specified window.                  |

## Help Menu Commands

|                              |   |   |
|------------------------------|---|---|
| <b>Help Topics</b>           |  | Offers you an index to topics on which you can get help.  |
| <b>About DigiTrak LWD...</b> |   | Displays the version number of the DigiTrak LWD software. |

## Information Fields

The steering tool application in the LWD software displays information grouped in related fields as discussed briefly below. These data fields are site information, job information, data tables, and chart area, as identified on the LWD Steering Tool Application Window shown at the start of this section. Detailed information on reading and editing the data fields are provided in the software's help files. Use the tool tip helper or view help topics for more information.

### Site Information

The site information section displays the job location and client information. Visible on the screen are:

- Site Name and Location – Job name and physical location of site.
- Client – Name of customer.
- Phone – Contact phone number.

All the address and contact information for the job, client, and contractor are listed on the printed document (see “Printing and Previewing Project Files” later in this section for more information regarding printed job files).

There are three ways to open the Site Information dialog box where site information can be edited: select the **Site Information...** command in the **Edit** menu; click on the site information icon on the toolbar; or double-click anywhere in the site information field of the application window.

## Job Information

The job information section displays statistical information about the job. This information includes:

- Date – Date the job was started, which is retrieved from the first uploaded data point.
- Data Points – Number of data points collected.
- Typical Rod Length – Typical length of the rods being used for the job. This length is taken from the Steering Tool Job Information dialog box, and it must be entered to enable the upload.
- Depth – Measurement units being used for depth (ft or m).
- Pitch – Measurement units being used for pitch (% or °).
- Elevation – Elevation of a survey marker near the bore (if used).
- Entry – Entry position relative to the (0, 0) coordinates on the charts (positive or negative distance on the profile view chart and left, L, or right, R, position on the plan view chart).

This information as well as the plan reference heading and roll offset (if used) are listed on the printed file (see “Printing and Previewing Project Files” later in this section for more information regarding printed job files).

The measurement units can be edited from the **Display Units...** command in the **Edit** menu or by clicking the edit display units icon on the toolbar.

There are three ways to open the Steering Tool Job Information dialog box, where you can edit the typical rod length, reference heading, reference elevation, and relative position at entry: select the **Job Information...** command in the **Edit** menu; click on the job information icon on the toolbar; or double-click anywhere in the job information field of the application window. The job information dialog box also automatically launches after a new job is created.

## Data Tables

Four types of data tables are provided under tabs in this area of the file: data points, topography, drill plan, and confidence points. Each type of data table is described below. View help files for additional information.

### Data Points

The data points table displays a list of all the data points in the job and all associated data. The columns in the table include:

- Rod ID – Number and status of the data point. Clicking on the profile or plan view charts will scroll the data points table to the selected data point.
- Length – Rod length recorded at that data point.
- Bore – Calculated length of the bore up to that data point.
- Pitch – Pitch value recorded at the specified data point. Units are those displayed in the job information field.
- Roll – Roll value in degrees recorded at the specified data point.
- Heading – Heading value in degrees recorded at the specified data point.
- Hdg.Dev. – Calculated deviation from the reference heading in degrees recorded at the specified data point.
- Dist. – Calculated aboveground distance the SST transmitter has traveled from the drill rig up to that data point.

- Depth – Calculated depth from the topological ground surface to the bore path at that data point. If no topography is entered, depth is undefined and this column will indicate “No Topo.” in the table.
- Rel.Dep. – Calculated depth relative to the 0 line of the Y-axis of the profile chart.
- Course R/L – Calculated distance right, R, or left, L, from the centerline of the plan view chart.
- Date/Time – Date and time the specified data point was recorded. This information does not show on the charts or printed report.
- Comments – User-entered comments.

Data points in the list can be edited, inserted, deleted, hidden, or removed from the chart and printed report. Only data points that have been manually inserted can be deleted.

A data point can be edited and commented on in the Edit Steering Tool Data Point dialog box at any time by right-clicking on a data point and selecting Edit or by double-clicking on a data point in the list or on the chart. Only measured values and comments can be edited. Calculated values are determined based on the measurements recorded or input by the user. See the *Inputting and Editing Drill Data* section for more information on recording and editing data points.

### Topography

The topography table displays a list of all of the topography points used to graph the ground surface terrain (green line) in the profile chart and to calculate depths. The columns in the table include:

- Topo.Pt. – Number of the topography point as it appears left to right on the profile chart.
- Dist. – Distance from where the tool enters the ground (Rod 0) to the specified topography point. Units are those displayed in the job information field for depth.
- Rel.Elev. – Vertical distance from the origin or the chart to the specified topography point. Units are those displayed in the job information field for depth.

Topography points can be edited, inserted, deleted, or imported into the topography table.

A topography point can be edited in the Edit Topo Data dialog box by right-clicking on the table and selecting Edit or by double-clicking on a topography point in the list or on the chart. See the *Inputting and Editing Drill Data* section for more information on importing, inserting, and editing topography points.

### Drill Plan

The drill plan table displays a list of all the points used to graph the planned bore path (gray line) on the profile and plan view charts. The columns in the table include:

- Plan Pt. – Number of the drill plan point as it appears left to right on the profile and plan view charts.
- Dist. – Horizontal distance from where the tool enters the ground (Rod 0) to the specified drill plan point. Units are those displayed in the job information field for depth.
- Rel.Dep. – Vertical distance from the origin of the profile chart to the specified drill plan point. Units are those displayed in the job information field for depth.
- Course R/L – Distance right, R, or left, L, from the reference heading line to the specified drill plan point on the plan view chart. Units are those displayed in the job information field for depth.

Drill plan data points can be edited, inserted, deleted, or imported into the drill plan table.

A drill plan point can be edited in the Edit Drill Plan Data dialog box by right-clicking on the drill plan point and selecting Edit or by double-clicking on the drill plan point in the list or on the chart. See the *Inputting and Editing Drill Data* section for more information on importing, inserting, and editing drill plan points.

### Confidence Points

The confidence points table displays a list of all the points physically measured during the bore and input into the steering tool file by the computer operator. Confidence points are used to override the calculated drill path and to force the graphed data to pass through the measured point. The use of confidence points requires topography and a drill path for reference. The columns in the table include:

- Conf.Pt. – Number of the confidence point as it appears left to right on the profile and plan view charts.
- Dist. – Distance from where the tool enters the ground (Rod 0) to the specified confidence point. Units are those displayed in the job information field for depth.
- Depth – Vertical distance from the terrain surface to the specified measured confidence point. Units are those displayed in the job information field for depth.
- Course R/L – Distance right, R, or left, L, from the reference heading line to the specified measured confidence point on the plan view chart. Units are those displayed in the job information field for depth.

Confidence points can be edited, inserted, deleted, or imported into the confidence points table.

A confidence point can be edited in the Steering Confidence Point dialog box by right-clicking on the confidence point in the table and selecting Edit or by double-clicking on the confidence point in the table or on the chart. See the *Inputting and Editing Drill Data* section for more information on importing, inserting, and editing confidence points.

### Chart Area

The profile and plan view charts give a graphical representation of the information contained in the data tables and can be annotated to provide additional details about the job. The common features of the two charts are discussed below. See the help topics in the LWD software for more information.

- Graphed Points – Data points, drill plan points, terrain (topology) points, and confidence points that have been logged or imported and have not been hidden or deleted display in the chart area.
- Axes – The X and Y axes of each graph are labeled for the type of data contained in the chart. The X-axis of each chart shows the horizontal distance from the drill. The Y-axis of each chart differs, as discussed below.
- Cursor Coordinates – When the cursor is placed anywhere in the chart area, the value of the coordinates at that position display. If the cursor is placed on a data point, all values recorded at that data point will display.
- Zoom – To zoom into an area of the chart, hold down the control button on your computer then click and hold (control-click) on your mouse while you drag the pointer through the area you wish to explode. Release the mouse button once the area is selected. To return the chart to its normal scaling, control-click anywhere in the chart area.

## Profile View Chart

The profile view area shows the bore's progress in a two-dimensional profile (depth/distance) view. As the bore progresses, and more data points are logged, an automatic scaling feature formats the plot area so that the entire bore remains viewable. If terrain and/or a drill plan is entered prior to drilling, the chart will automatically be scaled to show all available data. See **Profile Chart Properties...** under the **Edit** menu for information on manual scaling of the chart.

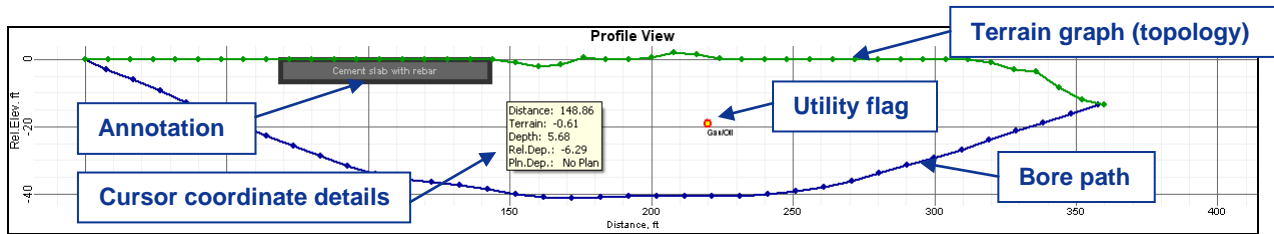

**Profile View Chart Area**

The Y-axis of the chart shows the vertical distance (relative depth and relative elevation) from the chart's origin.

Cursor coordinate details appear when you hover the mouse over the profile view chart, and data point details appear when you hover the mouse over a data point in the chart.

## Plan View Chart

The plan view chart is at the same horizontal position as the profile chart, but it is from a bird's-eye view.

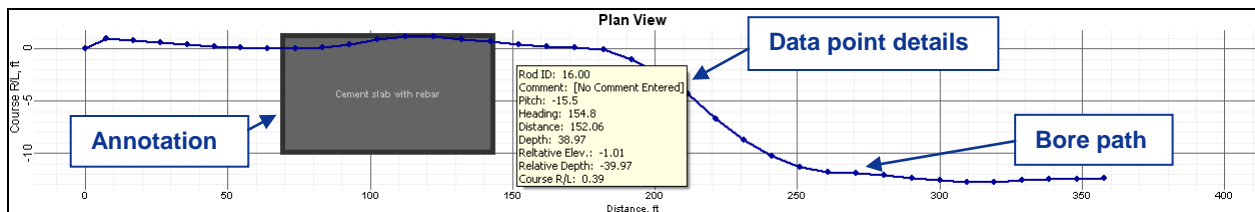

**Plan View Chart Area**

The Y-axis of the chart shows the right/left distance value from the heading reference line, where right (R) is a negative value and left (L) is a positive value.

Cursor coordinate details appear when you hover the mouse over the plan view chart, and data point details appear when you hover the mouse over a data point in the chart.

## Editing and Annotating Charts

The profile and plan view charts can be edited and annotated in a number of ways. Shapes and captions can be drawn directly on the charts to describe job site conditions and other points of interest using the **Edit** menu chart annotations commands. And the boundaries of the charts can be changed using the **Edit** menu chart properties commands. The help files in the LWD software provide full instructions on all editing capabilities. The instructions below are basic to getting started with the chart editing functions.

### Drawing Shapes and Adding Captions

There are four ways you can access the chart annotations dialog boxes where you can draw shapes and enter information to be included on the chart graph and printed report.

- Select the profile or plan chart annotations command from the **Edit** menu.
- Click on the edit profile or plan chart annotations icon on the tool bar.
- Place the mouse on an existing annotation and double-click to change its properties. NOTE: Captions cannot be edited in this manner; only objects.
- Hold the shift key down and use the mouse to draw a box around the area you would like a shape to appear on the chart. The Location area of the dialog box will automatically be filled with the coordinates of the box you drew.

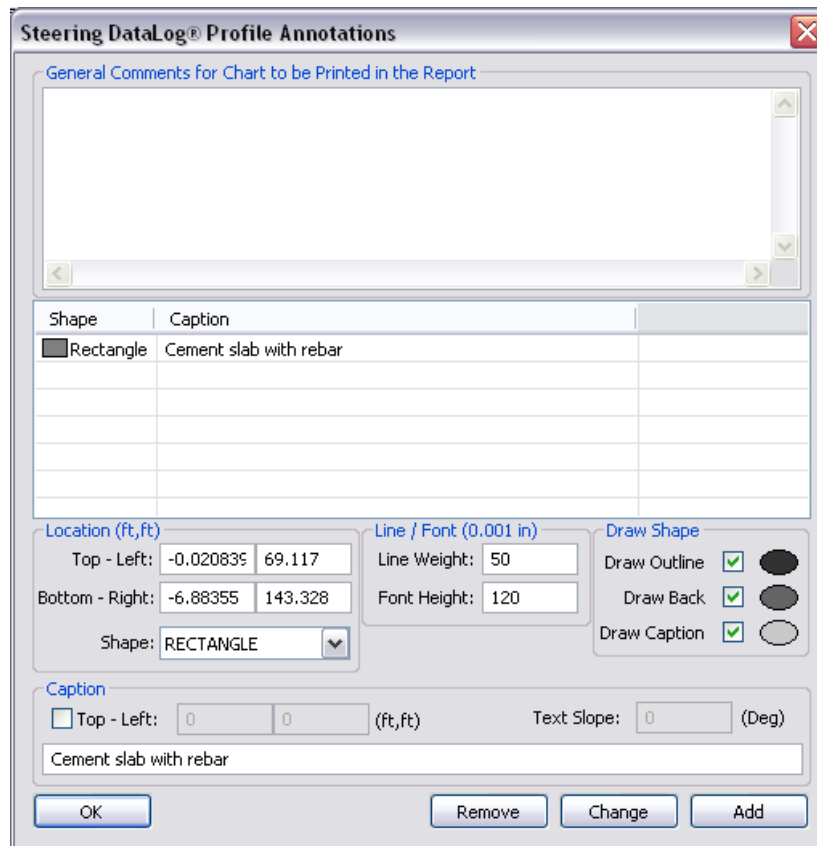

**Profile Chart Annotation Dialog Box**

Both the profile and plan chart annotation dialog boxes function in the same way; only the coordinates shown in the Location and Caption sections of the dialog boxes will be different. If you open the chart annotations dialog box using the **Edit** menu command or tool bar icon, you will need to enter the coordinates of the shape you wish to draw in the Location section of the dialog box.

### Selecting and Editing Shapes

Select the shape you would like to appear on the chart from the pull-down menu in the Location section of the chart annotations dialog box.

Adjust the line weight and font size in the Line/Font section of the dialog box.

Select which parts of the shape you would like to appear in the Draw Shape section of the dialog box.

The color of the different parts of the shape can be adjusted by double-clicking on the ellipses in the Draw Shape section of the dialog box.

### Adding and Editing Captions

Before a caption can be entered, the check box next to “Draw Caption” in the Draw Shape section of the chart annotations dialog box must be checked to activate the Caption section of the dialog box. With the Caption section active, type the words you would like to appear on the graph in the text box in this section. You do not have to draw a shape to add a caption.

If a shape is drawn, the caption will appear centered in the shape by default.

To change the location or orientation of where the caption appears, click in the box next to “Top - Left” in the Caption section of the dialog box. Enter the coordinates of where you would like the text to begin.

To change the orientation of the text, type the value of the slope of the text in the “Text Slope” text box.

### Editing Chart Properties

To open the profile or plan chart properties dialog boxes where properties such as chart boundaries and scaling can be adjusted:

- Select the profile or plan chart properties command from the **Edit** menu.
- Click on the edit profile or plan chart properties icon on the tool bar.

Automatic scaling is selected by default. Click in the box next to “Auto Scale” to adjust the horizontal or vertical scaling and chart boundaries. Then manually enter the coordinates of chart boundaries as you would like them to appear.

## Printing and Previewing Project Files

To preview the printed pages before you send the file to print, select **Print Preview** from the **File** menu or click on the print preview icon on the tool bar. To close the print preview window and return to the file, click on the Close button in the print preview window. To print the file from the print preview window, click on the Print button.

To edit printing properties such as the printer or paper size and orientation, select **Print Setup** from the **File** menu or click on the print setup icon on the tool bar.

There are three ways to print the job data: select **Print** from the **File** menu, click on the print icon on the toolbar, or click on the Print button in the print preview window. After selecting a print option, the Print dialog box will appear. Make any adjustments needed in the Print dialog box, then click on OK. If you have the Adobe Acrobat PDF writer software, you can select the Adobe PDF printer to print to a PDF file (see your Adobe software documentation).

The job data will print on at least three pages. The job information, including location, client, and contractor information, if entered, will appear on the first page, along with the statistical data about the job and any job comments. The profile and plan view charts will appear on the second page. The third page (and more if needed) will list the drill data. Data for data points that have been removed will not display. The topography survey data and drill data, if entered, will display.

## Saving Project Files

To save an open project file, select **Save** from the **File** menu or click on the save icon on the toolbar. If the file has already been named and saved, it will automatically be saved under its current file name and location. If the project has not yet been saved and named, then the Save As dialog box will open where you can enter the file name and select the save location. The default file name is Steering#.st5, where “#” represents a number that starts at 1 and advances automatically as files are saved.

To save an open file with a different file name or location, select **Save As** from the **File** menu. The Save As dialog box will appear, which automatically opens to the folder where the current file is saved. Change the file name and location as desired, then click the Save button. The open file will now have the new file name and/or location.

DCI recommends saving each job file with two different names in the event that one file becomes corrupted.

### E-mailing Report to Customer Who Does Not Have DigiTrak LWD software

The DigiTrak LWD software is able to generate a printed report or an electronic copy of your file, as discussed above under “Printing and Previewing Project Files.” In addition, electronic project files can be sent to and opened by anyone who has the DigiTrak LWD software.

If you want to send an electronic copy to a customer who does not have the LWD software, we suggest you use a document-generating printer driver to create a PDF file using any of the following:

- PrimoPDF – This free software is available for download online at [www.primopdf.com](http://www.primopdf.com). With this software installed, you can print the report to PrimoPDF instead of your printer and save the report as a PDF file. This file can then be attached to an e-mail message. Please refer to PrimoPDF for instructions in the use of this product.
- Bullzip PDF Printer – This free software is available for download online at [www.bullzip.com](http://www.bullzip.com). With this software installed, you can print the report to Bullzip PDF Printer and save the report as a PDF file. This file can then be attached to an e-mail message. Please refer to Bullzip for instructions in the use of this product.
- Microsoft XPS Printer – Microsoft has generated a nonstandard encapsulated postscript format called \*.xps. It is a standard Windows component and will probably appear in your printer list. Only Microsoft Internet Explorer can present this document type without a translator. If IE is not your default web browser, then you or your customer may not be able to view this file type. Please refer to <http://windows.microsoft.com/en-US/windows-vista/Print-to-the-Microsoft-XPS-Document-Writer> for instructions on use with your specific operating system.

Additional information can be found at the website: [help.digitrak.com](http://help.digitrak.com)

Once you have a document writer installed:

1. From the **File** menu or the toolbar, select the print option to open the Print dialog box.
2. Under Printer at the top, use the pull-down menu to select your PDF writer or Microsoft XPS Document Writer.
3. Click on the Properties button to open the properties dialog box, and then select portrait or landscape orientation (landscape is recommended).
4. Click on OK to save the orientation and close the properties dialog box.
5. Click on OK to save the file as a \*.pdf or \*.xps file type. The Save As dialog box will appear.
6. Input the name for your file in the file name text box.
7. Choose the location/folder where you want to save the file.
8. Click on OK to save the file.
9. Attach the saved PDF or XPS file to your e-mail message. The customer can view the file in a PDF compatible viewer such as Adobe Acrobat or a Microsoft XPS compatible viewer such as Internet Explorer.

As an alternative to e-mailing a PDF or XPS file, the printed document can be scanned and attached to an e-mail message.



**Notes**

## ***Inputting and Editing Drill Data***

You can manually edit SST project files by plotting the topography (topo) and the planned bore (drill plan) into the LWD software before, during, or after a bore. You can also import this information from a Microsoft Excel file, but it must be done prior to logging the SST bore.

### **Topography**

Topography data points that represent the horizontal distance from the drill rig and the relative elevation can be inserted, edited, imported, or removed from the topography table as described below. The topography data, or terrain graph, is shown as a green line on the profile view chart.

#### ***Inserting Topography Data Points***

To insert the first or next sequential topography point:

1. Right-click in any blank cell in the topography table, and then select Insert. A new topo point will display in the data table and on the chart with default values for distance and relative elevation.
2. Edit the topography data values, if necessary.

To add a topography point to the middle of the list:

1. Select the topo point prior to where the new point is to be inserted (you can click on the topo point in the data list or on the terrain graph).
2. Right-click on the highlighted point in the list, and then select Insert. A new topo point will display in the data table and on the chart with default values for distance and relative elevation.
3. Edit the topography data values, if necessary.

#### ***Editing Topography Data Points***

To edit an existing topography point:

1. Select the topo point to be edited (click on the topo point in the data list or on the terrain graph).
2. Right-click on the highlighted point in the data list and select Edit or double-click on the point in the list or on the terrain graph to open the Edit Topo Data dialog box.

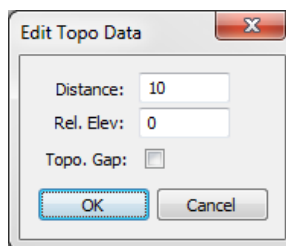

***Edit Topo Data Dialog Box***

3. Modify the data as desired in the dialog box. If you select the “Topo Gap” check box, the relative elevation will be disabled, and a gap will appear in the green terrain line on the profile view chart.
4. Click on OK to save your changes or Cancel to close without saving.

### Deleting Topography Data Points

To delete a topography data point from the list and chart:

1. Select the topo point to be deleted (click on the topo point in the data list or on the terrain graph).
2. Right-click on the highlighted point in the list and select Delete. The topo point will be deleted and the graph will adjust to connect the data points before and after the one that was deleted.

### Importing Topography Data Points

You must have a comma-separated-value (CSV) data file of the appropriate format to use the import function in the topography data table.

To create a CSV file of the appropriate format:

1. Open a spreadsheet program such as Excel.
2. Skip or enter notes and column headings on the first two rows. They will be ignored when the data is imported.
3. Beginning on the third row of the spreadsheet, enter two columns of data:
  - Column A – List the horizontal distance that each topo data point is from the drill rig in order from the closest to the farthest.
  - Column B – List the associated relative elevation (vertical distance from the surface of the ground at the drill rig) for each topo data point listed in column A. If no elevation data is entered for a data point, there will be a gap in the terrain graph for that distance.
4. Save the spreadsheet file in its standard format so that it can be found later.
5. Save the spreadsheet file again in the same location using the **File | Save As** command to save it as a CSV (\*.csv) file type, which is available as a pull-down option in most spreadsheet software. In some cases, you may have to change the file extension to \*.csv. Some features of the original spreadsheet may be lost when saving as this file type. The information required for importing the terrain data into the LWD software should be retained.
6. Close the CSV file.

To import a CSV file into the topography data table:

1. Right-click anywhere in the topography data table and select Import, or select the **File | Import** command and click on Terrain Survey Data... A Windows Explorer dialog box will display.
2. Locate and select the CSV file previously saved and click on Open. The topography data table will populate and the profile view chart will show the green terrain graph.

## Drill Plan

Drill plan data points include the horizontal distance from the drill rig, the relative depth, and the planned right/left course deviation. These drill plan points (Plan Pt.) can be inserted, edited, imported, or removed from the drill plan table as described below. The drill plan graph, which is the planned bore with the measured terrain, appears as shown below.

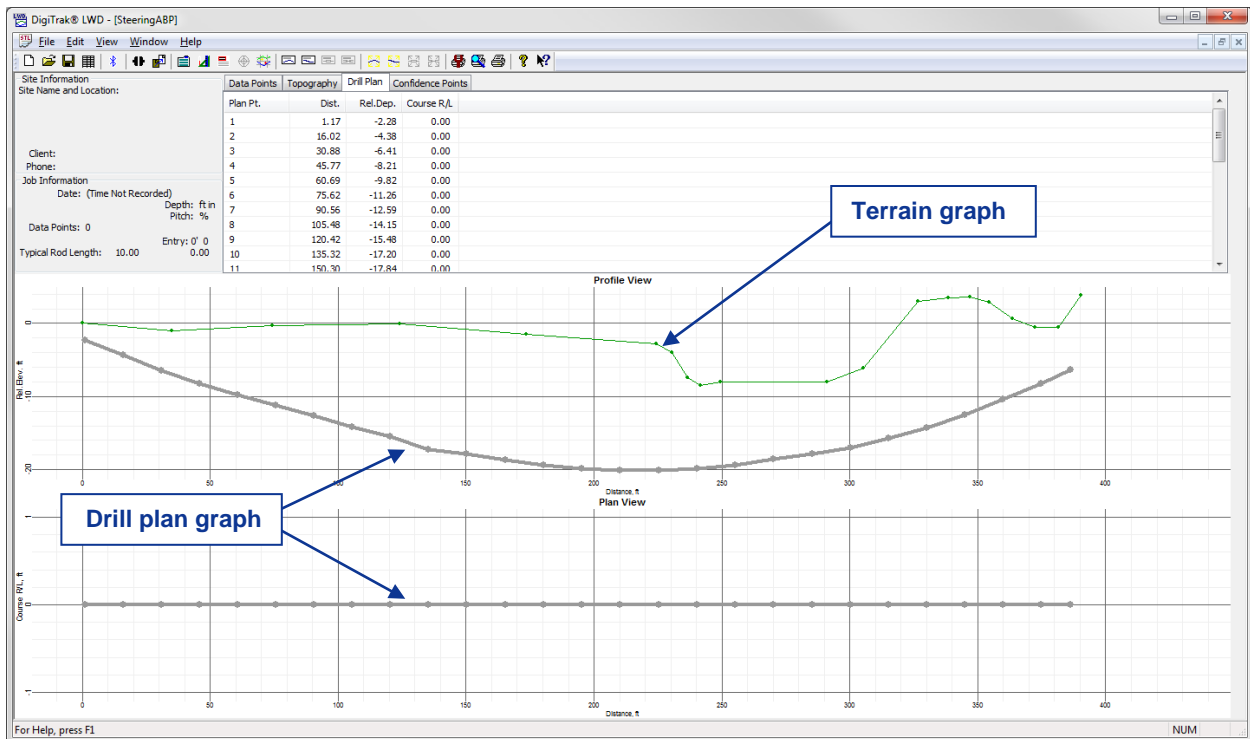

*Drill Plan with Terrain*

## Inserting Drill Plan Data Points

To insert the first or next sequential drill plan point on the table:

1. Right-click in any blank cell in the drill plan data table and select Insert. A new plan point will display in the data table and on the chart with default depth, relative elevation, and course deviation values.
2. Edit the drill plan data values, if necessary.

To add a drill plan point to the middle of the list:

1. Select the plan point prior to where the new point is to be inserted (click on the plan point in the data list or on the drill plan graph).
2. Right-click on the highlighted point in the list and select Insert. A new plan point will display in the data table and on the chart with default depth, relative elevation, and course deviation values.
3. Edit the drill plan data values, if necessary.

### Editing Drill Plan Data Points

To edit an existing drill plan point:

1. Select the plan point to be edited (click on the plan point in the data list or on the drill plan graph).
2. Right-click on the highlighted point in the data list and select Edit or double-click on the plan point in the list or on the drill plan graph to open the Edit Drill Plan Data dialog box.

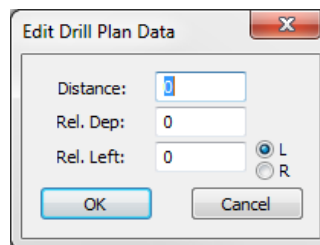

**Edit Drill Plan Data Dialog Box**

3. Modify the data as desired in the dialog box.
4. Click on OK to save your changes or Cancel to close without saving.

### Deleting Drill Plan Data Points

To delete a drill plan data point from the list and chart:

1. Select the plan point to be removed (click on the plan point in the data list or on the drill plan graph).
2. Right-click on the highlighted point in the list and select Delete. The plan point will be deleted and the graph will adjust to connect the data points before and after the one that was deleted.

### Importing Drill Plan Data Points

You must have a comma separated value (CSV) data file of the appropriate format to use the import function in the topography data table.

To create a CSV file of the appropriate format:

1. Open a spreadsheet program such as Excel.
2. Skip or enter notes and column headings on the first two rows. They will be ignored when the data is imported.
3. Beginning on the third row of the spreadsheet, enter three columns of data:
  - Column A – List the horizontal distance that each drill plan data point is from the drill rig in order from the closest to the farthest.
  - Column B – List the associated relative depth (vertical distance from the surface of the ground at the drill rig) for each plan point listed in column A. If no depth data is entered for a plan point, there will be a gap in the drill plan profile graph for that distance.
  - Column C – List the associated planned course deviation (right/left distance from the reference heading line) for each plan point listed in column A. If no depth data is entered for a plan point, there will be a gap in the drill plan view graph for that distance.
4. Save the spreadsheet file in its standard format so that it can be found later.
5. Save the spreadsheet file again in the same location using the **File | Save As** command to save it as a CSV (\*.csv) file type, which is available as a pull-down option in most spreadsheet software. In some cases, you may have to change the file extension to \*.csv. Some features of the original spreadsheet may be lost when saving as this file type. The information required for importing the terrain data into the LWD software should be retained.
6. Close the CSV file.

To import a CSV file into the drill plan data table:

1. Right-click anywhere in the drill plan data table and select Import, or select the **File | Import** command and click on Drill Plan Data... A Windows Explorer dialog box will display.
2. Locate and select the CSV file previously saved and click on Open. The drill plan data table will populate, and the profile and plan view charts will populate with all entered data including the gray line representing the drill plan graph.

## Confidence Points

Confidence data points can only be entered if there is terrain data and there is a drill path (drill data points). Confidence data points include the horizontal distance from the drill rig, the relative depth, and the planned course deviation (right/left). A confidence point can be inserted, edited, imported, or removed from the drill plan table as described below. Only one confidence point can be entered per drill data point (or per drill rod).

To insert a new confidence point:

1. Place your mouse on the chart area where you would like the confidence point to display, and then hold down the control and shift buttons and click the mouse (control-shift-click). The Steering Confidence Point dialog box will display.

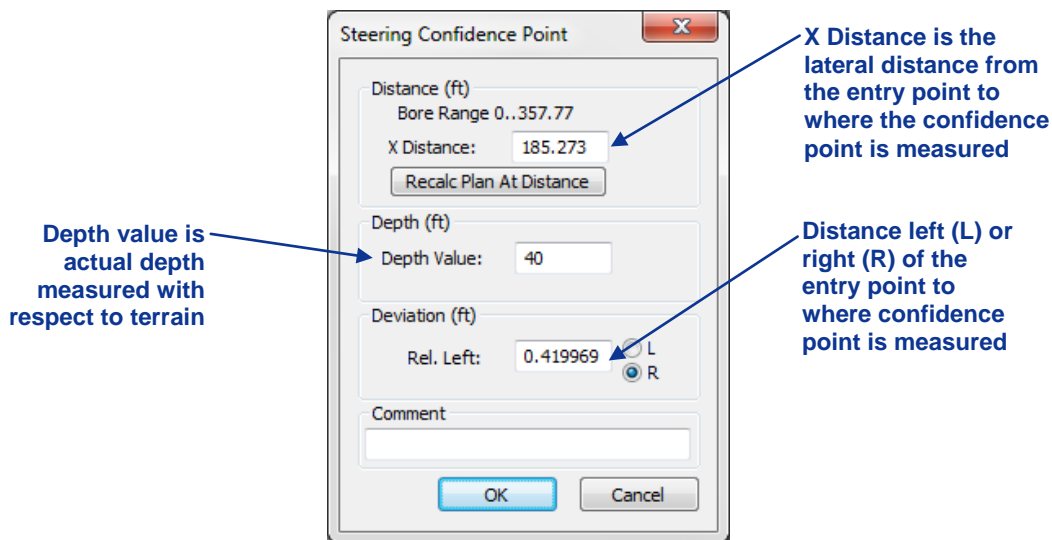

**Steering Confidence Point Dialog Box**

2. Enter the requested information and click on OK. The confidence point will appear on the graph as a highlighted point and display in the confidence points data table. The confidence point data will override the calculated drill path and force it to pass through the measured point.

To edit an existing confidence point:

1. Right-click on the confidence point in the data table and select Edit or double-click on the confidence point in the graph to open the Steering Confidence Point dialog box.
2. Enter the requested information and click on OK.

To delete a confidence point:

1. Select the confidence point to be deleted (click on the confidence point in the data table or on the confidence point in the graph).
2. Right-click on the highlighted point and select Delete. The confidence point will be deleted from the graph and data table. The graph will display the original calculated value for depth.

## Job Information

The Steering Tool Job Information dialog box allows you to edit such fixed data as the typical rod length, the reference heading, the reference elevation, and the relative position of the tool at entry. There are three ways to open the Steering Tool Job Information dialog box:

- Select the **Job Information...** command in the **Edit** menu.
- Click on the job information icon on the toolbar.
- Double-click anywhere in the job information field of the application window.

The Steering Tool Job Information dialog box also automatically launches after a new job is created.

### Steering Tool Job Information Dialog Box

You must enter a typical rod length (cannot be 0) in the Rod Length Information field. The rod length units may be feet (ft) or meters (m) and can be changed in the **Edit | Display Units** menu.

In the Reference Heading area, enter the same reference heading value (unit in degrees) that you have set in the remote display (it can be 0). To use the heading recorded at Rod 0 as the reference heading, check the box next to “Use Rod 0 Ref. Hdg.”

In the Survey Point Elevation Change area of the dialog box, the elevation units may be feet (ft) or meters (m) and can be changed and can be changed in the **Edit | Display Units** menu. Check the box next to “Do Not Use Reference Elevation” if the bore is not to be mapped in reference to a surveyed elevation marker near the bore. This value will appear in the profile chart title line.

If the drill enters the ground at some elevation other than the ground topography at the start of a bore, in a pit for example, then enter the depth deviation from the ground (the 0 reference line of the profile view of the bore) next to “Rel. Elev. At Entry” (-2 in the example above).

If the drill enters the ground at some distance left, L, or right, R, of where the reference heading was set, enter the lateral distance of the offset next to “Lat. Offset At Entry” (5 R in the example above).

## Upload Control

The Steering Tool Data Upload Control dialog box is used to view and record live data. You can log rods (data points), edit the logged rod length and heading, pull back recorded rods, and restore pulled back rods, as well as view measurement data and deviation from the plan if a drill plan is used. There are two ways to open the Steering Tool Data Upload Control dialog box:

- Select the **Upload Control...** command in the **File** menu.
- Click on the upload control icon on the toolbar.

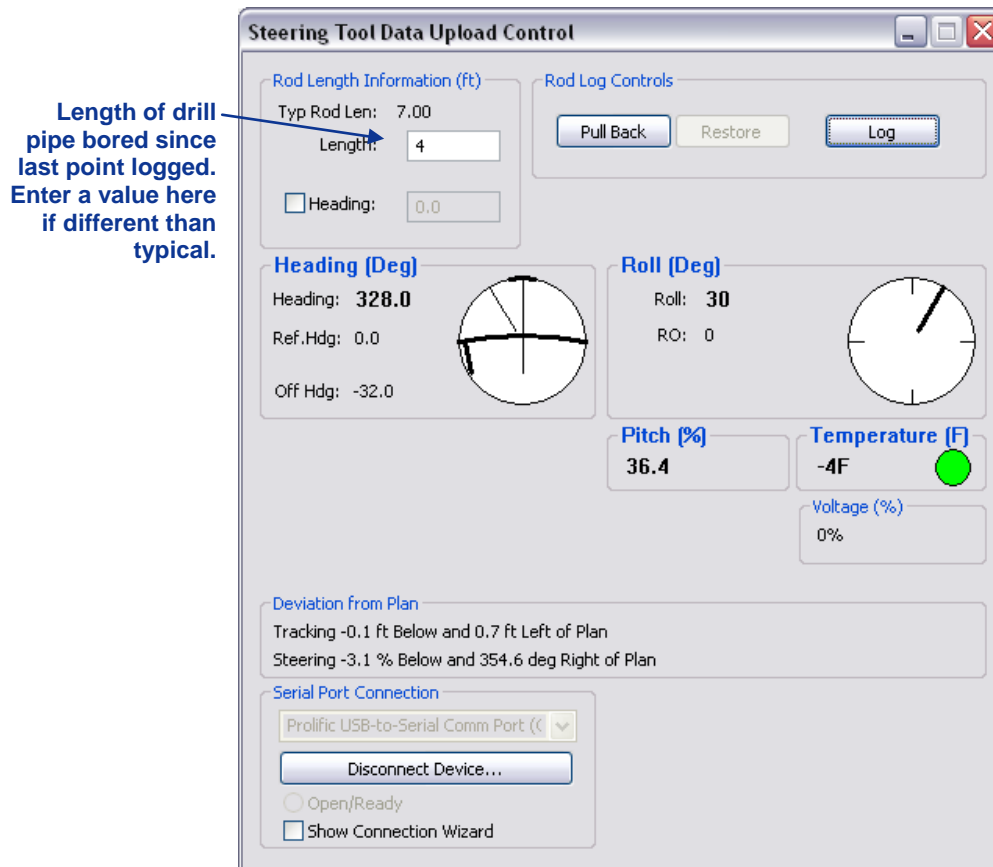

**Steering Tool Data Upload Control Dialog Box**

Once the upload control dialog box is opened, you can hide it so that you can more easily access these controls on the main application screen by clicking on the upload control icon on the toolbar. Click on it again or select **Upload Control...** from the **File** menu to again display the dialog box.

In the Rod Length Information area, the Typ Rod Len is the typical rod length defined in the Steering Tool Job Information dialog box; it cannot be edited here.

In the Length textbox, you can input the next recorded data point and record it for the next logged rod, if it will be different than the typical rod length. **NOTE:** If a partial rod length is used, this field will automatically be filled with the length remaining to finish the whole rod based on the typical rod length. For example, the above length input was 4, so the next data point will show 3 for this value to finish the 7 ft typical rod length.

Click on the check box next to “Heading” to enter a heading value (in degrees) for the next recorded data point and to override the measured heading. **NOTE:** This manual override of the heading value is used when the magnetometer does not provide a valid heading due to metallic objects around the transmitter.

Under the Heading field, the value is the tool’s measured heading (in degrees); Ref.Hdg is the reference heading input in the Steering Tool Job Information dialog box; and Off Hdg is the difference between the measured value and reference value of the heading. Off Hdg is negative when the offset is pointing to the left of the reference heading as indicated in the upload control dialog box.

## Steering Tool Data Points

Steering tool data points appearing in the data points table can be edited, inserted, removed, or hidden using the right-click function. A data point that is edited will force surrounding data to be recalculated. A data point that is inserted will appear in the data table and on the graph with default values calculated according to surrounding data. A data point that is removed will remove the data from the drill path calculation and graph. A data point that is hidden will remove the data point from the graph but the information contained in the data point will continue to be used for drill path calculations.

### Editing Steering Tool Data Points

To edit the pitch, heading, and rod length information recorded at a data point:

1. Open the Edit Steering Tool Data Point dialog box by double-clicking on the data point to be edited in the data point table or on the graph or right-clicking on the data point in the table and selecting Edit.



**Edit Steering Tool Data Point Dialog Box**

2. Modify the data as required.
3. Click on OK to save changes or Cancel to close without saving.

### Inserting Steering Tool Data Points

To insert a steering tool data point:

1. Right-click on the data point prior to where the new data point is to be inserted.
2. Select Insert. A new data point (Rod ID) will display in the data table and on the chart with default calculated values. The inserted data point will be denoted with an "I" in the table to indicate it is inserted rather than recorded.
3. Edit the data values, if necessary.

### **Removing Steering Tool Data Points**

To remove a steering data point from the table and chart calculations:

1. Right-click on the data point to be removed.
2. Select Remove. The data point will be removed from the graph and none of its data will be used for calculating the drill path. The point will show as removed in the table.

To restore a removed data point:

1. Right-click on the data point to be restored.
2. Select the checkmark next to "Remove" to uncheck the remove option and restore the data point.

### **Hiding Steering Tool Data Points**

To hide a steering data point from appearing on the graph:

1. Right-click on the data point to be hidden.
2. Select Hide. The data point will be removed from the graph, but its data will still be used for calculating the drill path. The point will show as hidden in the table as indicated by the grayed out rod next to the Rod ID.

To restore a hidden data point:

1. Right-click on the data point to be restored.
2. Select the checkmark next to "Hide" to uncheck the hide option and restore the data point.



**Notes**

3-3500-00-A1

## **Appendix A: System Specifications and Maintenance Requirements**

The power requirements and environmental requirements for the DigiTrak F5 SST system components are listed below. General maintenance requirements for the SST transmitter and the multi-function cable box (MFCB) are provided on the following page.

### **Power Requirements**

| <b>Device (Model Number)</b>             | <b>Operational Voltage</b>                | <b>Operational Current</b> |
|--|---|----------------------------|
| DigiTrak SST Transmitter (SST)           | 9–28 V $\overline{\text{---}}$ (nominal)  | 10 W max                   |
| DigiTrak F5 SST Receiver (F5R)           | 14.4 V $\overline{\text{---}}$ (nominal)  | 350 mA max                 |
| DigiTrak F Series Remote Display (FSD)   | 14.4 V $\overline{\text{---}}$ (nominal)  | 220 mA max                 |
| DigiTrak MFD Remote Display (MFD)        | 14.4 V $\overline{\text{---}}$ (nominal)  | 220 mA max                 |
| DigiTrak Multi-Function Cable Box (MFCB) | 12–28 V $\overline{\text{---}}$ (nominal) | 6 A max                    |

### **Environmental Requirements**

| <b>Device</b>                     | <b>Relative Humidity</b> | <b>Operating Temperature</b> |
|-----------------------------------|--------------------------|------------------------------|
| DigiTrak SST Transmitter          | <100%                    | -4° to 131°F (-20° to 55°C)  |
| DigiTrak F5 SST Receiver          | <90%                     | -4° to 140°F (-20° to 60°C)  |
| DigiTrak FSD Remote               | <90%                     | -4° to 140°F (-20° to 60°C)  |
| DigiTrak MFD Remote               | <90%                     | -4° to 140°F (-20° to 60°C)  |
| DigiTrak Multi-Function Cable Box | <90%                     | -4° to 140°F (-20° to 60°C)  |

### General SST Transmitter Care Instructions

- Do not pull on the transmitter's cable. A cable transmitter extraction/insertion tool, which is essentially a threaded metal rod, is provided with the transmitter and is available through any authorized DigiTrak dealer. It is used for inserting and extracting the cable transmitter into or out of the housing. Two threaded holes (1/4"-20 thread) are provided at the back of the cable transmitter for threading the extraction tool.
- If the cable wire becomes exposed at the base of the transmitter, the cable should be trimmed and reinstalled or replaced.
- Instructions and parts for replacing the cable are provided in the Replaceable Wire Kit (DCKIT) sent with the cable system and available through any authorized DigiTrak dealer.
- The SST transmitter must be kept at least 5 ft (1.5 m) away from all magnets including the remote display, which has a magnetic mount that will damage the transmitter. A protective magnetic shield is provided with the SST transmitter and is available through any authorized DigiTrak dealer. The magnetic shield should be placed on the end of the SST transmitter at all times when the transmitter is not in use.
- Placing tape around the fiberglass tube of the transmitter, if space allows, will keep the fiberglass protected from most corrosive environmental wear.
- Send in the Product Registration Card for the 90-day Limited Warranty.

### General Cable Box Care Instructions

- Do not disassemble. The cable box contains no user-serviceable parts.
- Clean exterior with a damp cloth.
- Do not submerge.
- Do not pressure wash.
- Ensure all ports remain clean and clear of debris. Pressurized air or a soft brush may be used to remove debris from the cable ports.
- A wire brush may be used to clean the power post.
- Send in the Product Registration Card for the 1-year Limited Warranty.

## **Appendix B: Transmitter Wire Repair or Replacement**

You will need to replace the cable lead and other end cap components in the cable transmitter when the wire shows wear, twists, or abrasions. This involves removing the transmitter end cap to access the cable lead connection to the transmitter base. The Replaceable Wire Kit (DCKIT) includes enough parts to replace the cable lead two times. You will also need a standard screw driver.

The DCKIT contains:

- Two cable leads
- Four Torx screws
- Four lock washers
- Four 2-021 O-rings
- Two screw insulators
- Two 2-106 O-rings
- Two brass set screws
- Three white nylon set screws
- One T15 Torx wrench
- One each 5/64", 1/8", and 3/32" Allen wrenches
- One tube of Noalox anti-oxidant compound

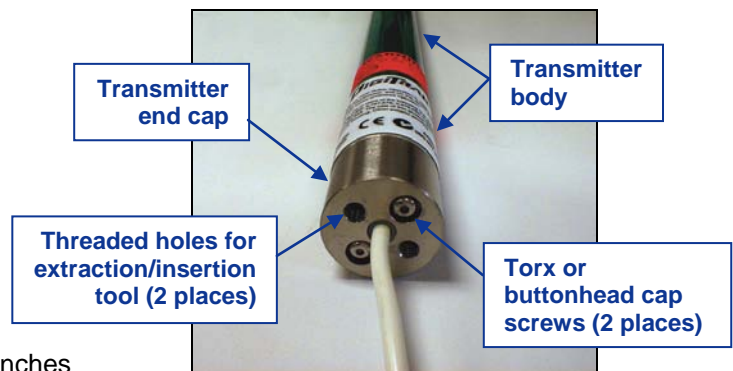

**Wireline End of Cable Transmitter**

To disassemble and reassemble the transmitter end cap:

1. Using the 5/64" Allen wrench or the T15 Torx wrench, depending on the screw type installed, remove the two Torx or buttonhead cap screws and lock washers.
2. Pull the end cap from the transmitter base.
3. Identify the deepest set screw depression in the base. Using the 1/8" Allen wrench or a standard screw driver, remove the white nylon set screw. There will be a brass set screw behind the nylon screw that holds the cable in place. NOTE: Do not tamper with the brass set screw and O-ring located on the opposite side of the base in the shallow depression.
4. Using the 3/32" Allen wrench, remove the brass set screw inside the transmitter base that holds the cable lead to the base.
5. Remove the old wire, the 2-106 O-ring, and the screw insulator. Removing the old wire from the base may require some force.
6. Install a new insulator and 2-106 O-ring onto a new cable lead, and insert the wire in the base. (Be sure that only 5/16" of the wire coating is stripped back from the end of the tinned cable lead.)
7. Install a new brass set screw using the 3/32" Allen wrench. Push the cable lead in while tightening the set screw to ensure a good connection.
8. Using the standard screw driver or the 1/8" Allen wrench, install a new white nylon set screw into the side of the transmitter base.

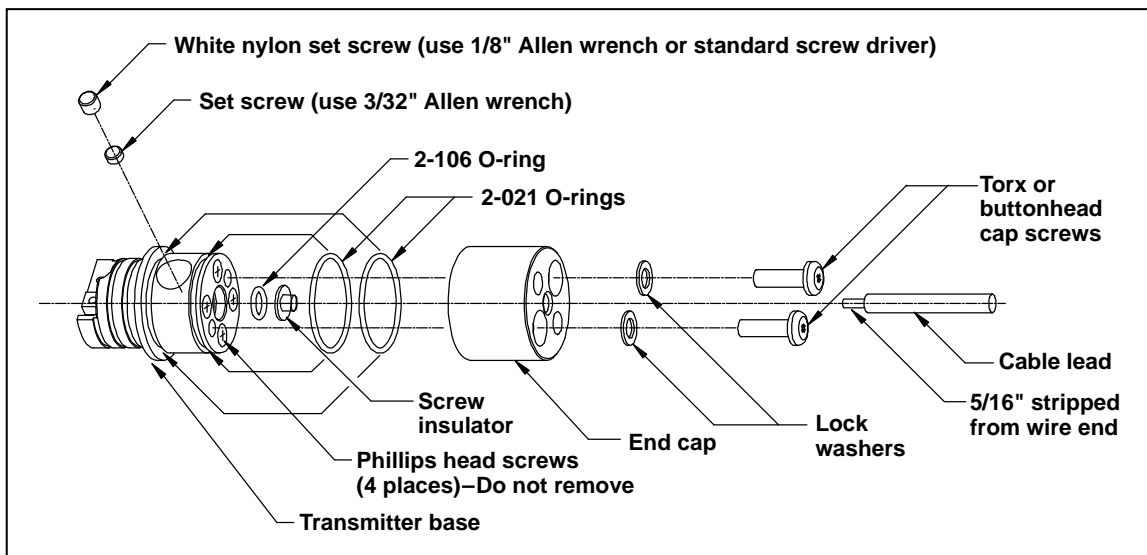

***Exploded View of Cable Transmitter Base and End Cap Assemblies***

9. Install two new 2-021 O-rings.
10. Coat the top and sides of the base with a thin layer of Noalox to prevent electrical corrosion (do not substitute with standard grease).
11. Replace end cap and line up the screw holes on the base with the nonthreaded holes on the cap.
12. Install two new lock washers and Torx screws, and tighten the screws in place using the T15 Torx wrench.

**NOTE:** Use care when threading the Torx screws into the base to avoid cross threading.

## LIMITED WARRANTY

Digital Control Incorporated (“DCI”) warrants that when shipped from DCI each DCI Product will conform to DCI’s current published specifications in existence at the time of shipment and will be free, for the warranty period (“Warranty Period”) described below, from defects in materials and workmanship. The limited warranty described herein (“Limited Warranty”) is not transferable, shall extend only to the first end-user (“User”) purchasing the DCI Product from either DCI or a dealer expressly authorized by DCI to sell DCI Products (“Authorized DCI Dealer”), and is subject to the following terms, conditions and limitations:

1. A Warranty Period of twelve (12) months shall apply to the following new DCI Products: receivers/locators, remote displays, battery chargers and rechargeable batteries, and DataLog® modules and interfaces. A Warranty Period of ninety (90) days shall apply to all other new DCI Products, including transmitters, accessories, and software programs and modules. Unless otherwise stated by DCI, a Warranty Period of ninety (90) days shall apply to: (a) a used DCI Product sold either by DCI or by an Authorized DCI Dealer who has been expressly authorized by DCI to sell such used DCI Product; and (b) services provided by DCI, including testing, servicing, and repairing an out-of-warranty DCI Product. The Warranty Period shall begin from the later of: (i) the date of shipment of the DCI Product from DCI, or (ii) the date of shipment (or other delivery) of the DCI Product from an Authorized DCI Dealer to User.

2. DCI’s sole obligation under this Limited Warranty shall be limited to either repairing, replacing, or adjusting, at DCI’s option, a covered DCI Product that has been determined by DCI, after reasonable inspection, to be defective during the foregoing Warranty Period. All warranty inspections, repairs and adjustments must be performed either by DCI or by a warranty claim service authorized in writing by DCI. All warranty claims must include proof of purchase, including proof of purchase date, identifying the DCI Product by serial number.

**3. The Limited Warranty shall only be effective if: (i) within fourteen (14) days of receipt of the DCI Product, User mails a fully completed Product Registration Card to DCI; (ii) User makes a reasonable inspection upon first receipt of the DCI Product and immediately notifies DCI of any apparent defect; and (iii) User complies with all of the Warranty Claim Procedures described below.**

## **WHAT IS NOT COVERED**

This Limited Warranty excludes all damage, including damage to any DCI Product, due to: failure to follow DCI’s operator’s manual and other DCI instructions; abuse; misuse; neglect; accident; fire; flood; Acts of God; improper applications; connection to incorrect line voltages and improper power sources; use of incorrect fuses; overheating; contact with high voltages or injurious substances; use of batteries or other products or components not manufactured or supplied by DCI; or other events beyond the control of DCI. This Limited Warranty does not apply to any equipment not manufactured or supplied by DCI nor, if applicable, to any damage or loss resulting from use of any DCI Product outside the designated country of use. By accepting a DCI Product and not returning it for a refund within thirty (30) days of purchase, User agrees to the terms of this Limited Warranty, including without limitation the Limitation of Remedies and Liability described below, and agrees to carefully evaluate the suitability of the DCI Product for User’s intended use and to thoroughly read and strictly follow all instructions supplied by DCI (including any updated DCI Product information which may be obtained at the above DCI website). In no event shall this Limited Warranty cover any damage arising during shipment of the DCI Product to or from DCI.

User agrees that the following will render the above Limited Warranty void: (i) alteration, removal or tampering with any serial number, identification, instructional, or sealing labels on the DCI Product, or (ii) any unauthorized disassembly, repair or modification of the DCI Product. In no event shall DCI be responsible for the cost of or any damage resulting from any changes, modifications, or repairs to the DCI Product not expressly authorized in writing by DCI, and DCI shall not be responsible for the loss of or damage to the DCI Product or any other equipment while in the possession of any service agency not authorized by DCI.

DCI reserves the right to make changes in design and improvements upon DCI Products from time to time, and User understands that DCI shall have no obligation to upgrade any previously manufactured DCI Product to include any such changes.

**THE FOREGOING LIMITED WARRANTY IS DCI'S SOLE WARRANTY AND IS MADE IN PLACE OF ALL OTHER WARRANTIES, EXPRESS OR IMPLIED, INCLUDING BUT NOT LIMITED TO THE IMPLIED WARRANTIES OF MERCHANTABILITY AND FITNESS FOR A PARTICULAR PURPOSE AND ANY IMPLIED WARRANTY ARISING FROM COURSE OF PERFORMANCE, COURSE OF DEALING, OR USAGE OF TRADE, ALL OF WHICH ARE HEREBY DISCLAIMED AND EXCLUDED.** If DCI has substantially complied with the warranty claim procedures described below, such procedures shall constitute User's sole and exclusive remedy for breach of the Limited Warranty.

## LIMITATION OF REMEDIES AND LIABILITY

In no event shall DCI or anyone else involved in the creation, production, or delivery of the DCI Product be liable for any damages arising out of the use or inability to use the DCI Product, including but not limited to indirect, special, incidental, or consequential damages, or for any cover, loss of information, profit, revenue or use, based upon any claim by User for breach of warranty, breach of contract, negligence, strict liability, or any other legal theory, even if DCI has been advised of the possibility of such damages. In no event shall DCI's liability exceed the amount User has paid for the DCI Product. To the extent that any applicable law does not allow the exclusion or limitation of incidental, consequential or similar damages, the foregoing limitations regarding such damages shall not apply.

This Limited Warranty gives you specific legal rights, and you may also have other rights which vary from state to state. This Limited Warranty shall be governed by the laws of the State of Washington.

## WARRANTY CLAIM PROCEDURES

1. If you are having problems with your DCI Product, you must first contact the Authorized DCI Dealer where it was purchased. If you are unable to resolve the problem through your Authorized DCI Dealer, contact DCI's Customer Service Department in Kent, Washington, USA at the above telephone number between 6:00 a.m. and 6:00 p.m. Pacific Time and ask to speak with a customer service representative. (The above "800" number is available for use only in the USA and Canada.) Prior to returning any DCI Product to DCI for service, you must obtain a Return Merchandise Authorization (RMA) number. Failure to obtain an RMA may result in delays or return to you of the DCI Product without repair.
2. After contacting a DCI customer service representative by telephone, the representative will attempt to assist you in troubleshooting while you are using the DCI Product during actual field operations. Please have all related equipment available together with a list of all DCI Product serial numbers. It is important that field troubleshooting be conducted because many problems do not result from a defective DCI Product, but instead are due to either operational errors or adverse conditions occurring in the User's drilling environment.
3. If a DCI Product problem is confirmed as a result of field troubleshooting discussions with a DCI customer service representative, the representative will issue an RMA number authorizing the return of the DCI Product and will provide shipping directions. You will be responsible for all shipping costs, including any insurance. If, after receiving the DCI Product and performing diagnostic testing, DCI determines the problem is covered by the Limited Warranty, required repairs and/or adjustments will be made, and a properly functioning DCI Product will be promptly shipped to you. If the problem is not covered by the Limited Warranty, you will be informed of the reason and be provided an estimate of repair costs. If you authorize DCI to service or repair the DCI Product, the work will be promptly performed and the DCI Product will be shipped to you. You will be billed for any costs for testing, repairs and adjustments not covered by the Limited Warranty and for shipping costs. In most cases, repairs are accomplished within 1 to 2 weeks.
4. DCI has a limited supply of loaner equipment available. If loaner equipment is required by you and is available, DCI will attempt to ship loaner equipment to you by overnight delivery for your use while your equipment is being serviced by DCI. DCI will make reasonable efforts to minimize your downtime on warranty claims, limited by circumstances not within DCI's control. If DCI provides you loaner equipment, your equipment must be received by DCI no later than the second business day after your receipt of loaner equipment. You must return the loaner equipment by overnight delivery for receipt by DCI no later than the second business day after your receipt of the repaired DCI Product. Any failure to meet these deadlines will result in a rental charge for use of the loaner equipment for each extra day the return of the loaner equipment to DCI is delayed.